

SUNANGEL S 46



OPERATING INSTRUCTIONS



Ergoline

Ergoline

1006840-00 / us / kn / 11.2008

OPERATING INSTRUCTIONS

USA

CDN

SUNANGEL S 46

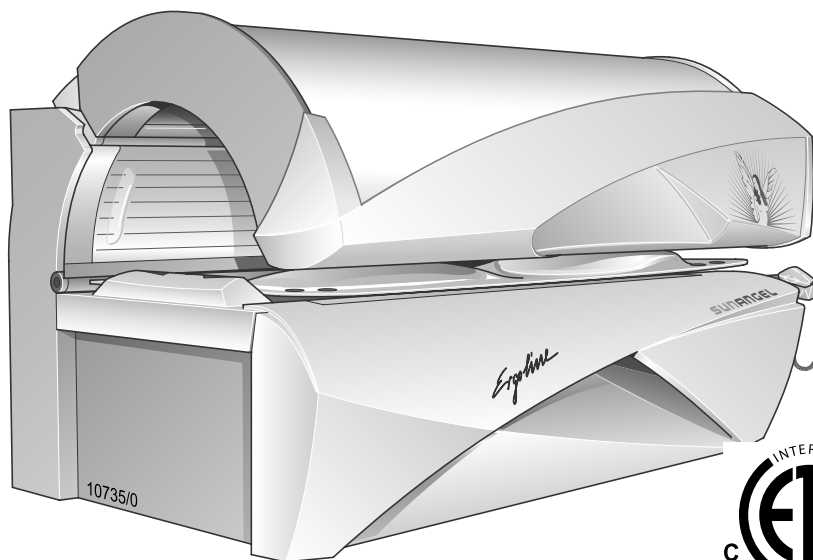

Identify your tanning device

For contact with Customer Services, please write down the device number of your tanning device.

--	--	--	--	--	--	--	--

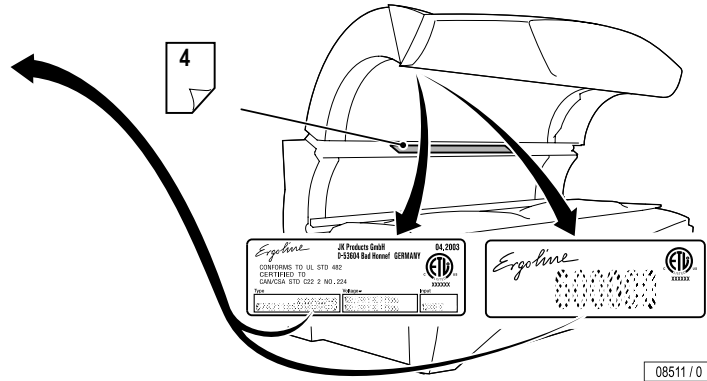
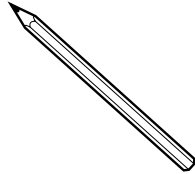

Global Service USA
A Div of JK Products & Services, Inc.
#1 Walter Kratz Drive
Jonesboro, AR 72401



☎ 800-445-0624
📠 870-935-9046

e-mail: support@jkamerica.com
<http://support.jkamerica.com>

Skin types

Skin types

For the recommended exposure schedule see page 4.

Skin type I (Sensitive):

Invariably gets sunburn, accepts little natural sunlight and does not tan.

Skin type II (Fair):

This is the individual that usually burns easily and severely, tans minimally or lightly and peels.

Skin type III (Average):

Often referred to as “Average” complexion, burns moderately and tans about average.

Skin type IV (Brown):

This individual burns minimally, tans easily and above average with each exposure.

Skin type V (Dark Brown):

This individual's system rarely burns, tans easily and substantially.

Tanning times

DANGER ULTRAVIOLET RADIATION

Follow instructions. Avoid over-exposure as with natural sunlight. Over-exposure can cause eye and skin injury and allergic reactions. Repeated exposure may cause premature aging of the skin and skin cancer.

Maximum Tanning Time is 20 Minutes

Recommended Exposure Schedule

Skin Type	Week 1	Week 2	Week 3	Week 4	Weekly Subsequent Treatments
	1st - 3rd Treatments	4th - 6th Treatments	7th - 10th Treatments	11th - 15th Treatments	
I - Sensitive	NOT ADVISED	NOT ADVISED	NOT ADVISED	NOT ADVISED	NOT ADVISED
II - Fair	0.75 MED*	1.5 MED	3.0 MED	4.0 MED	4.0 MED
III - Average	0.75 MED	1.5 MED	3.0 MED	4.0 MED	4.0 MED
IV - Brown	0.75 MED	2.0 MED	3.0 MED	4.0 MED	4.0 MED
V - Dark Brown	0.75 MED	2.0 MED	3.0 MED	4.0 MED	4.0 MED

* MED = Minimal Erythral Dose

WEAR PROTECTIVE EYEWEAR! FAILURE TO DO SO MAY RESULT IN SEVERE BURNS OR LONG TERM INJURY TO THE EYES.

Certain medications or cosmetics may increase your sensitivity to the ultraviolet radiation. Consult a physician before using sunlamps if you are using medications, have a history of skin problems or believe yourself to be especially sensitive to sunlight. If you do not tan in the sun, you are unlikely to tan from the use of this product.

This unit utilizes UVA lamps. Replace only with Ergoline SUNANGEL 200W TYPE A and TYPE B, Ergoline ULTRA 520W C12645 (high pressure/ facial-tanner) and Ergoline SUNANGEL 25W (shoulder-tanner) or recognized equivalents. To obtain recommended exposure at a minimum distance of 1/2" (13mm) measured with a standard ruler, lie on acrylic surface of lounge and lower canopy. Canopy will stop at the correct distance from lounge acrylic surface.

Warning: The use of any other position may result in overexposure!

Tanning can begin on a regular basis. An appearance of tanning normally appears after a few exposures and maximizes after four (4) weeks of exposure following the recommended exposure schedule for skin type. In order to provide for maintenance of a tan a maximum of two (2) weekly 20 minute sessions is recommended from the fifth week onward.

Do not tan more than once in a 48 hour period.

Use protective eyewear (Part No. Schmerler 2255 Red or recognized equivalents) when equipment is on. Read and follow instruction booklet before using this product. To avoid electrical shock during maintenance disconnect power from unit.

Part No: 1503864-00-



Note:

Description of skin types see Page 3.

11623 / 0

"This product is in conformity with performance standards for sunlamp products under CFR21 Part 1040."

Table of contents	7
General safety instructions and information	9
Description	19
Operation	22
Maintenance	61
Technical data / appendix	115
Index	125



Foreword

Dear Customer,

The Ergoline device you have purchased is a technically advanced and powerful product. Your device was manufactured with the greatest care and precision. It went through numerous quality and safety checks in order to guarantee trouble-free, safe operation. Nonetheless, you can also make a significant contribution to your long-term satisfaction with your device. Following the tips and instructions in the instruction manual will ensure you enjoyment and pleasure with your device.

If you have any questions, we are always available to answer them.¹⁾

Yours sincerely

JK-Products, Inc.

- Read and observe the information in this instruction manual. This will enable you to prevent accidents and provide you with a reliable device ready for use.
- Always observe current legal and other regulations and legal requirements as well as the applicable environmental protection regulations.



Note:

We reserve the right to make technical changes to the illustrations and specifications in this instruction manual. Reprinting and reproduction, in whole or in part, of this manual is only permitted with our previous written approval and with the source specified.

1) ☎(800) 643 0086

Table of contents

Skin types	3
Tanning times	4
Important safety notes	9
Safety notices	9
Instructions pertaining to a risk of fire, electric shock, or injury	10
Instructions pertaining to a risk of damage to the machine	12
Information for the studio operator	13
Meaning of symbols	13
Intended use	16
Obligations of the studio operator	16
Guidelines	16
Export	16
MP3 music (optional)	17
Product information	18
Environmental protection information	18
Description	
Equipment	19
Description	20
Accessories	21

Operation	
Mandatory reading	22
Operation overview	23
Tanning	25
Use the sunbed – but use it properly!	25
Start of tanning	26
Interrupt or end tanning session	28
Regulating the facial tanner	32
Tempronic – regulating the temperature	37
Regulating body cooling	41
Switching AROMA on and off	43
Switching AQUA MIST body nozzle on and off	45
Switching AQUA MIST head nozzle on and off	47
MP3 player connection	49
Voice Guide	51
Listening to Info texts	53
Selecting the audio system (channel)	55
Adjusting the volume and switching-off the audio systems	58
Running time of accent lights	60





Maintenance

Safety information for maintenance and care	61
Power Off device and secure against being switched on again	63
Malfunctions	64
Maintenance overview	65
Cleaning	66
Cleaning and maintenance intervals	69
Relamping / maintenance instructions	75
Sensor and base station cleaning	76
Inserting the chip card of the new lamp set	77
Cleaning/replacing UV low-pressure lamps in the sunbed base	79
Cleaning/replacing UV low-pressure lamps in the shoulder tanner	81
Cleaning/replacing UV low-pressure lamps in the canopy	85
Cleaning/replacing UV low-pressure lamps in the facial tanner	87
Cleaning/replacing interior lighting	89
Cleaning/replacing UV high-pressure lamps and filter panels in the side section	91
Cleaning or replacing UV high-pressure lamps and filter panels in the canopy	94
Cleaning/replacing accent lights in the canopy	98
Cleaning/replacing accent light in front panel	100
Cleaning the base filters	102
Cleaning/replacing filter mats in the canopy	104
Cleaning/replacing filter mats in shoulder tanner	105
Temptronic: Emptying the condensation tank and cleaning the filter in the air condition	107

Replacing the AROMA tank	110
AQUA MIST system: Replacing the canister	112

Technical data

Connected load, power and noise level	115
Installed lamps	116
Spare parts and accessories	118
Dimensions	119
Installation location	120

JK-Products, Inc. – Limited Warranty	121
---	------------

Index	125
------------------------	------------

Presettings – see “Presettings”, Order No. 1001971

Troubleshooting – see “Error codes”, Order No. 800751

**Timer operation – see manual “Intellitran Remote Timer”,
Order no. 801129**

Important safety notes

Safety notices

Description of warning signs

Danger notices, damage to persons:



DANGER!

Type and source of danger, e.g. “DANGER – High voltage!”

Description of the consequences, e.g. “You can be killed or injured by an electric shock!”

Countermeasures:

- Disconnect device from power supply before opening.
- Do not reach into the inside with the device switched on.

Warning notices, damage to persons:



WARNING!

Type and source of danger, e.g. “Warning – hot surface!”

Description of the consequences, e.g. “You can burn your hand (skin, face)!”

Countermeasures:

- Do not touch hot parts and nearby surfaces.
- Wait until hot parts and surfaces have cooled down.

Caution notices, damage to property:



Caution!

The word “Caution” with this label points out that danger for devices, materials and the environment can be expected here.

Important information:



Note:

This symbol does not identify safety notices, but states information for a better understanding of the processes.



Instructions pertaining to a risk of fire, electric shock, or injury



DANGER!

DANGER – High voltage!

You can be killed or injured by an electric shock!

Assembly and electrical connection must comply with national and local regulations.

- The device may only be assembled, installed, upgraded or repaired by specially trained and instructed personnel.



WARNING!

WARNING – ultraviolet radiation!

Unprotected tanning may result in eye injury and eye diseases.

The unprotected eye can become inflamed on the surface, and in certain cases the retina can be damaged by excessive radiation. Cataracts can form after frequently repeated exposure to radiation.

- **Inform users to use the included protective goggles that block UV** (Order No. 84592-..).



WARNING!

WARNING – ultraviolet radiation! Follow instructions!

Failure to use protective eyewear may result in severe burns or other eye injury. If discomfort develops, discontinue use and consult a physician.

- A person who does not tan in the sun most likely will not tan from the use of this device. Persons with very sensitive skins (skin type I) must not use the unit, as with this skin type tanning is impossible without damaging the skin (e.g. sunburn).
- Individuals with acute sunburn, individuals who have had or have skin cancer, or individuals who are at increased risk of skin cancer, must not use the system.
- UV devices must not be used without taking medical advice if unexpected effects, such as itching, occur within 48 hours of the first session.
- The sunbed must never be used if a filter panel is missing or damaged, or the timer is defective!
- UV light from the sun or UV systems can cause injuries to the skin or eyes. This biological effect is dependent on the sensitivity of the individual's skin and on the type and amount of UV light.
- As with natural sunlight, overexposure can cause eye and skin injury, sunburn, and allergic reactions.
- Persons who have used spray tanning or self tanning lotions should not use this equipment.



WARNING!

- Repeated exposure may cause premature aging of the skin and skin cancer.
- Medications or cosmetics applied to the skin, may increase sensitivity to ultraviolet light.
- A person having a history of skin problems should consult a physician before use.



WARNING!

WARNING – ultraviolet radiation!

Danger of long-term consequences.

- Overexposure should be avoided.
- The elderly should not use this equipment.
- Nursing infants and small children through age 7 years may not use this device.
- The following applies to minors under the age of 18 years: Only use tanning devices in agreement with a parent or guardian, or after consulting a physician.
- While there is no immediate clinical evidence of UVA exposure and its effects upon expectant mothers, it is strongly advised that expectant mothers be discouraged from using the tanning unit.



WARNING!

WARNING – risk of infection!

Infections can be transferred through skin contact.

All items/equipment components, with which the user can come into contact during tanning, must be disinfected after every tanning session:

- Sunbed acrylic
- Headrest
- Handles and control panel
- Adjustable air nozzles
- Protective goggles
- MP3 cable
- Sensor and base station

For fast, hygienic proper cleaning, use a specially developed fast disinfectant cleaner.



Note:

To ensure thorough disinfection, always adhere to the reaction time specified for the disinfectant.

Follow the manufacturer's instructions for use.





Note:

Occasionally, persons using the tanning device will experience a slight reddening of the skin – usually in small patches – after the second or third session. This redness is often accompanied by an itching sensation. This may be nothing more than a heat “rash” caused by heat from the lamps within the device. It is generally very limited and caused by constant contact of the skin with the acrylic surface. It should go away within approximately 24 hours and should not reappear. This rashing can be lessened or prevented by applying moisturizer lotion to the affected area after the tanning session is completed.

- Follow instructions.
- The time between the first two tanning sessions must be at least 24 hours.
- Increasing tanning also requires an extension of the exposure time (= radiation time) or after a certain degree of tanning has been achieved, a further intensification is not possible. However, the radiation time may not be extended as desired within the scope of the permissible radiation doses! Therefore, only a certain degree of final tanning dependent on the skin type can be achieved without endangering your health.
- Inform users about proper tanning.

Instructions pertaining to a risk of damage to the machine

















CAUTION – danger of overheating!

Danger of overheating by obstruction of the air routing.

- Do not change, obstruct or block the air inflow and outflow area to the device or make any unauthorized changes to the device. The manufacturer shall bear no liability for damage or injuries resulting from such actions.
- Before putting a tanning device into operation, the transport pallet must be removed from under the device. Danger of overheating by obstruction of the air routing.

Information for the studio operator

Meaning of symbols

	Inform Customer Services		UV low-pressure lamp(s)
	Manufacturer		Starter for low-pressure lamp(s)
	Part/article number (for orders)		UV high-pressure lamp(s)
	Danger! Switch off the device. – Unplug the device from the power supply		Filter panels
	Ergoline key		Cleaning and disinfectant agents
	Do not touch, hot surface!	...	Continuation of work steps on next page
	Suction cup		End of work step
	Low-pressure lamp(s)		Automatic mode



Information for the studio operator



AUTO

Function can also be used in automatic mode



No cosmetics



Display of tanning time



Display of run-on time (fan run-on)



Fault display (example),
see separate manual



Display of Info Track 1 (from 1-17)



Display: internal music channel 1 (channel 1)
Factory setting: 1 channel
customer service can setup additional channels



Display: external device connected



Display: MP3 player connected



Display when adjusting the volume

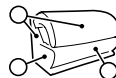

Description



Accent lights



Body cooling with
AQUA SOLAR WITH SKIN+ ADDITIVE



Fragrance "Heaven"



Press button



e.g.
2s

Press button for 2 seconds





















Duration: 3 minutes



Loudspeaker

Information for the studio operator

	Headphone connection		Test with test strip
	MP3 player connection		Draining
	see separate manual		Visual inspection
	Caution, safety switch!		Air condition
	Unscrew/release screw		Filter/filter mat
			
	Tighten/lock screw		Filter and filter mats must not be damp.
			
	Cleaning		Chipcard of lamp set
	Replacing		
	Clean or replace depending on soiling		
			



Intended use

The tanning device is intended exclusively for cosmetic tanning of the human skin.

- The device is meant for commercial use only, not for home use.
- This device is used for tanning one adult person at a time.
- The user wears suitable eye protection that blocks UV radiation during tanning.

Any other use shall be considered improper. The manufacturer cannot be held liable for damage or injuries resulting from this. The operator bears the sole risk for this.

The proper use also includes compliance with the manufacturer's instructions, operating and maintenance conditions. This device may only be operated, maintained and repaired by persons familiar with these tasks and who have been informed of the dangers involved.

Obligations of the studio operator

- As the operator you are responsible for informing users on possible risks during tanning.
- All danger and safety labels attached to the device must be observed! Do not remove them!
- No safety equipment (e.g. panel switch) may be removed or deactivated which can impair the safe operation of the device!
- The device may only be operated in a serviceable condition!
- The operator is bound to ensure that the equipment is handled correctly.

Guidelines

This device was built conforming to UL STD 482, and is certified to CAN/CSA STD C22.2 2 No. 224.

Export

We would like to point out that these devices are exclusively intended for use in the USA and Canada and may not be exported to other countries and operated there! The manufacturer assumes no liability whatsoever in the event of non-compliance! We explicitly emphasize that high liability risks may occur for the exporter and/or the operator in the event of non-compliance.

MP3 music (optional)

If an MP3 player is used privately during tanning, then this does **not** constitute a public performance in the sense of copyright law, so that no reporting or fee obligation to the corresponding copyright owning company in respect of copyright exists on the part of the studio operator.

The same regulations apply for the official use of MP3 music files as for other music sources: As studio owner you are only allowed to use original audio CDs, MCs, audio DVDs etc. in your premises and / or play them in the MP3 music module fitted to the Ergoline professional sunbed if you have already obtained the corresponding performing rights.¹⁾

Copy-protected audio CDs, MCs, audio DVDs etc., as well as the tracks included on these media, are not allowed to be converted to MP3 format and / or stored on hard discs, audio CDs, MCs, audio DVDs etc. when software and / or computer programs are used for this purpose which cancel or avoid the copy-protection included on the storage media.

At the request of the external staff or any other controlling body of the responsible company, you must always be in a position to prove that you have purchased the performance rights by showing the relevant authorisation.

As long you follow the advice given above and have gained of the necessary rights, you may convert your original audio CDs, MCs, audio DVDs etc. to the MP3 format required for the player. However, you may only create one copy (either a duplicate or a conversion to MP3 format)

for each audio CD, MC, audio DVD etc. for which you have obtained the legal rights. The original sound storage medium must be stored and is not allowed to be used at the same time.

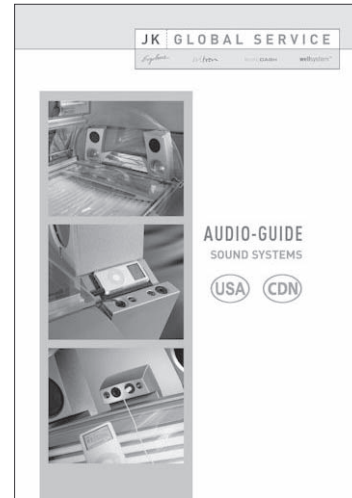

1006019

11604 / 0



Note:

Further information you can find in the Audio Guide, which is available for download at www.jkamerica.com.

1) from the company responsible for the allocation of commercial performing rights in your country (in Germany: GEMA/GVL)



Product information

Acrylic glass panels



The acrylic glass panels for the tanning devices are produced of acrylic glass developed especially for this application. The acrylics used are characterized by a particularly high UV permeability and resistance, as well as an easy-care, hygienic surface that is gentle to the skin.

The acrylic glass panels are formed to their shapes for the specific devices in a technically complex production process. Despite state-of-the-art production know-how, the presence of minor spots, air bubbles or streaks in the acrylic panels is unavoidable. In addition, microfine hairline cracks can occur on the bed surface during operation.

These occurrences are material-dependent and are unavoidable in processing, however have no significant effect on the use or value and can therefore not be recognized as defects.



CAUTION!

Cosmetics or sun screen products must be removed prior to using the sunbed as they can cause damage (e.g. fine cracks on the surface) when used continuously.

Environmental protection information

Environmental Declaration – The JK Corporate Group

The JK corporate group is subject to the strict regulations of EC Directive 761/2001 and the ISO 14001 standard, and undergoes regular internal and external environment audits performed by trained auditors.

Environmental regulations – disposal of lamps

UV low-pressure lamps and UV high-pressure lamps contain fluorescent materials and other waste containing mercury.

According to the national waste disposal laws and in accordance with the municipal waste regulations, proof must be provided of the proper disposal of UV lamps.

Your local environmental agency will be happy to assist you with the disposal of UV lamps.

Packaging

All packaging consists of 100 % recyclable materials.

Disposal of recyclable materials

The device has been produced of recyclable materials. When being scrapped later, the device must be disposed of properly. Sun Ergoline will provide you with information on the content or potential hazards of the materials used.

Equipment

This instruction manual covers all standard and optional components/ functions to be taken into consideration during operation and/or maintenance.

The control panel differs according to the various equipment: the only visible buttons are those that can be operated, i.e. the corresponding function must be part of the device's equipment.

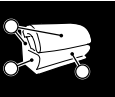

Description

1. Facial tanner (UV high pressure lamps)
2. Shoulder tanner with audio system
loudspeaker (2.1), headphone connection (2.2),
MP3-connection (2.3)
3. Sensor and base station
4. UV low pressure lamps, base
5. Partition
6. Acrylic cover, base
7. Infrared interface
8. Body cooling air nozzles, foot end
9. UV low pressure lamps, side section
10. UV low pressure lamps, canopy
11. AQUA MIST AROMA system nozzles
12. Body cooling air nozzles
13. Control panel
14. Adjustable air nozzles face cooling / AROMA
15. Interior lighting
16. Accent lighting, canopy
17. Accent lighting, front panel

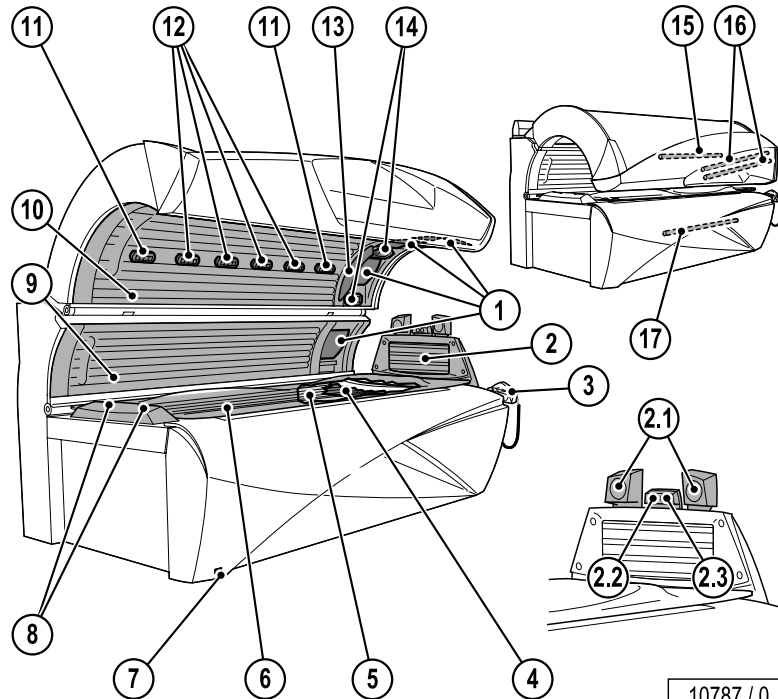

10787 / 0

Accessories

18. Central air discharge socket

19. Ambient Light

Some accessory parts are taken into account in the maintenance schedule beginning on page 69 and in the spare parts section from page 118. However this does not automatically mean that your device is fitted with this equipment.

Order numbers and more accessories are listed in the sales documentation and the planning manual.

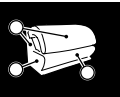
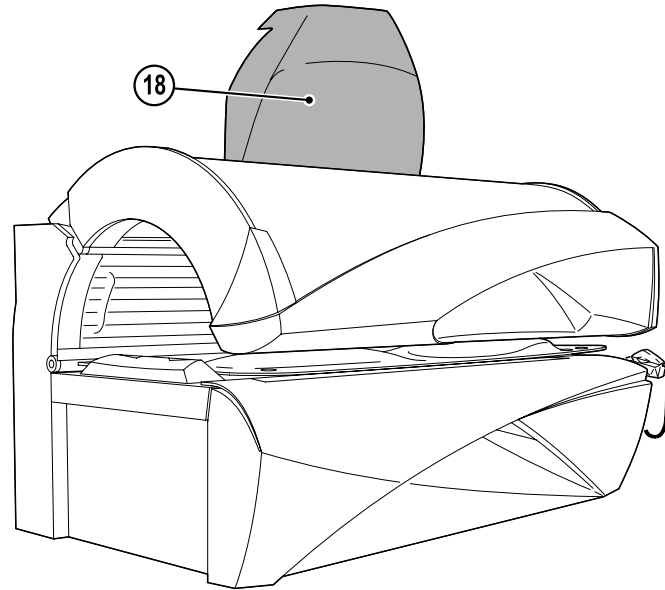

10966 / 0

Operation

Mandatory reading

Always read and follow all instructions for proper usage prior to allow anybody using a tanning device. The operating instructions included with this device must always be followed to prevent possible injuries or to reduce them to a minimum.

Inform users

- to use provided UV-blocking protective eyewear whenever the equipment is energized.
- to follow the exposure schedule in accordance with their skin type. Failure to do so may result in overexposure.

A tanning system is not a toy. You cannot vary the strength of the lamps in your unit.

Should you have any questions regarding the proper use of your tanning system, contact Global Service USA at:

☎ 800 445 0624

7:00 a.m. to 7:00 p.m. (CT)



Warning – ultraviolet radiation!

Danger of skin injuries and skin diseases!

- The sunbed must never be used when a filter panel is missing or damaged, or the timer is defective!

WARNING!



Note:

When describing the operation, the tanning device is often shown with the canopy open. During tanning the canopy must always be closed.

Proper operation is not possible with the canopy open.



Operation overview

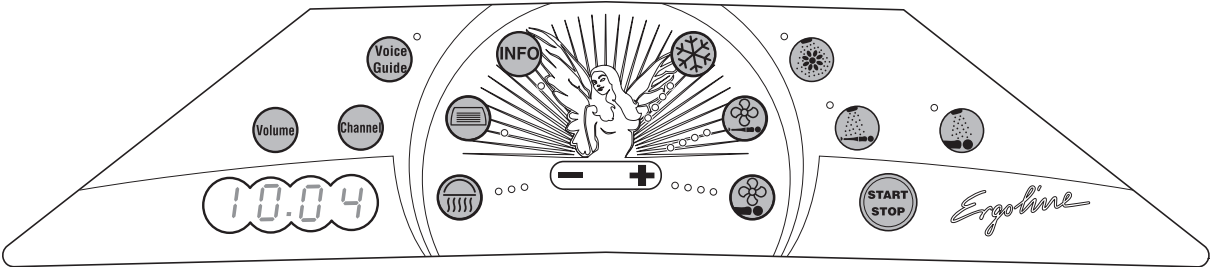

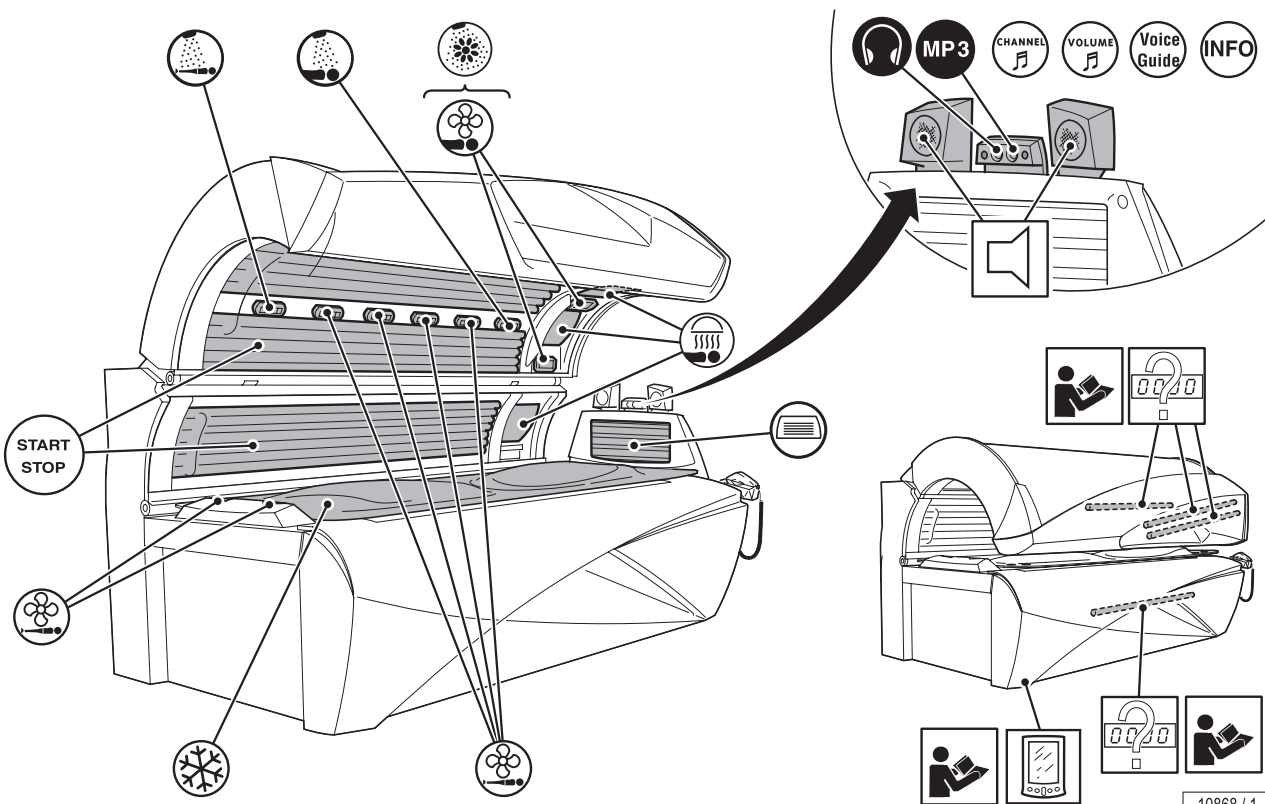

Tanning

Use the sunbed – but use it properly!

A few things need to be noted to get maximum enjoyment from a sunbed. Here are some answers to some frequently asked questions.

Make-up on the sunbed?

Please remove make-up or don't use make-up while tanning. Clean skin absorbs UV light better.

A wide variety of ingredients are found in cosmetics. Again, whether these are emulsifiers, greases, or so-called scents – in conjunction with UV radiation, these can cause allergic reactions of the skin.

Accordingly, a must before using a sunbed is: Remove all make-up. This is essential. Make-up clogs the pores in the face. The UV light from a sunbed re-opens these clogged pores so that not only does the light penetrate the skin, but also the allergenic components of the make-up.

A further negative consequence of make-up is that the appearance of the skin deteriorates irreversibly over a period of time. However good a decent make-up might be – in conjunction with UV light, it causes more harm than good. Therefore: Remove all make-up before a session on your sunbed – it will be much better applied afterwards.

Showering after leaving the sunbed?

The browning is in the skin, not on it. Therefore you cannot wash it off. Treat your skin to a moisturizing cream after showering.

Are medications and the sunbed compatible?

It is known that some medications increase the skin's sensitivity to UV light. This probability is particularly high with antibiotics, sulphonamides, psychiatric drugs, tranquilizers, anti-diabetes treatments and diuretics. Sun creams which contain psoralen or kumarin also increase skin sensitivity. If you are in any doubt, first ask your doctor - then you can enjoy the sun at no risk.

Contact lenses on the sunbed?

The answer is: Yes! Like any other sunbed user, contact lens wearers should also wear special protective goggles which protect the eyes against UV radiation. To guarantee better protection, wearers of spectacles and contact lenses can ask their optician for exchange contact lenses with UV protection. The UV-A and UV-B filters built into exchange contact lenses will protect the cornea and the internal parts of the eye against almost 100% of the energy in UV radiation.

This will benefit sunbed users not only in the open air, but on the sunbed itself. For more information, ask your optician or optometrist.



...

Start of tanning

Automatic mode

The following applies in automatic mode:

- The tanning time is the same for all users.
- The user's skin type is determined by 2 readings taken using a calibrated sensor (calibration: see separate instructions).
- The output from the UV lamps is optimised for the skin type reading and the existing degree of tanning.
- The power of the UV high voltage lamps can be reduced manually.

First tanning session

The first tanning session must be a test session (for further information see page 29).

Leave the sensor in the base station; the required test dose of 100 J/m² will be emitted.



Timer in automatic mode

If the device is operated with a timer (e.g. coin/token operation), the tanning time is preset to 20 minutes – see separate instructions “Presettings”.



Danger!

Risk of burns!

Skin areas measured for skin type should be free of cosmetics or lotions. Do not measure on hairy parts of the body, on moles or visible veins!



Danger!

Risk of burns!

Do not use this SUNANGEL sunbed, if you have an artificial tan resulting from a selftanner or a spray-on tanning device. If you are unsure or have further questions, please consult with the salon staff.

Preparation time

Before the UV lamps turn on, you have a few minutes to prepare yourself. During the preparation time you can switch on the UV lamps at any time by pressing the START/STOP button.

- Remove your clothes and all jewelry.
- Remove make-up and other cosmetics.
- When using the sunbed for the first time, a test session is required: see page 29.
Otherwise use sensor (see page 30).
- Remove glasses. Contact lenses can be worn under the protective goggles.
- Put on the protective goggles.
- Lie down on the bed surface.
- Close the canopy.
- Press the START/STOP button.

Closing the canopy

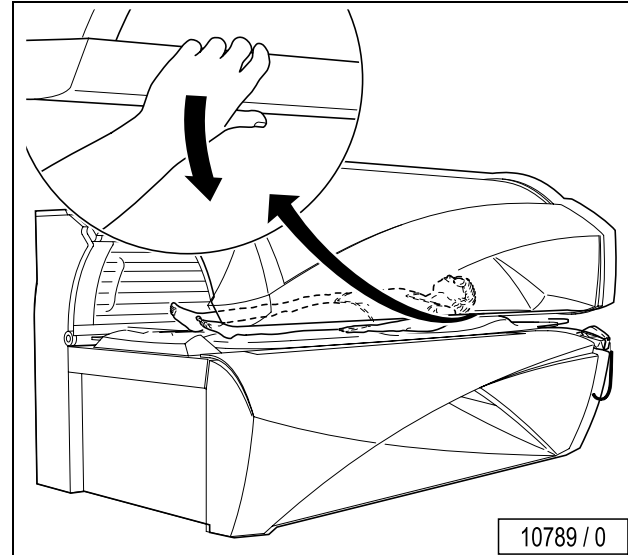

Interrupt or end tanning session

The tanning session ends automatically after the preset time has run down. The internal fan continues to run for approx. three (3) minutes to sufficiently cool the device.

- To interrupt a tanning session, press button START/STOP anytime during a session.
- Press START/STOP again to restart the lamps.

Settings on start-up

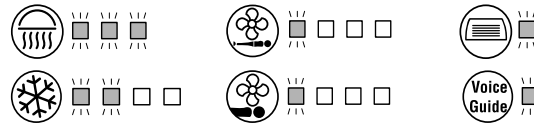
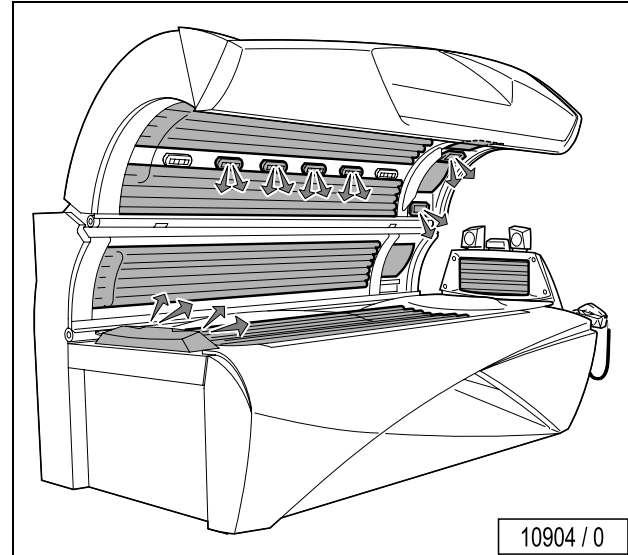

...

First tanning session (without automatic mode)

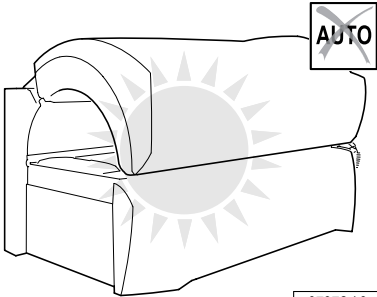

07972 / 0

Test session



1

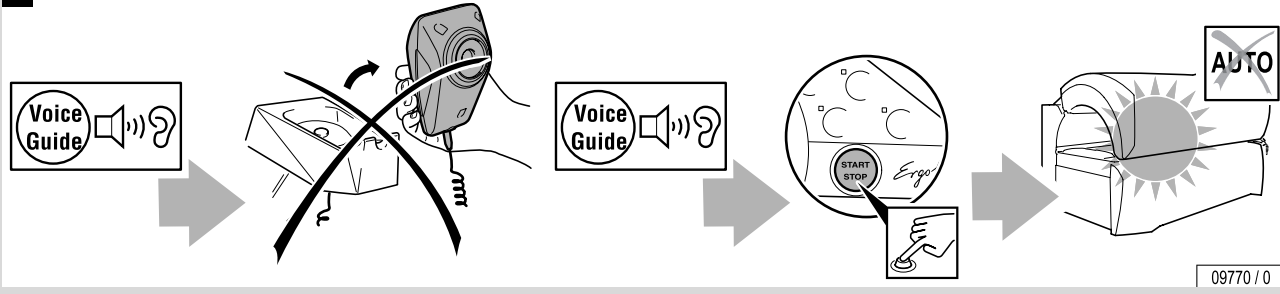

09770 / 0



Start (automatic mode)

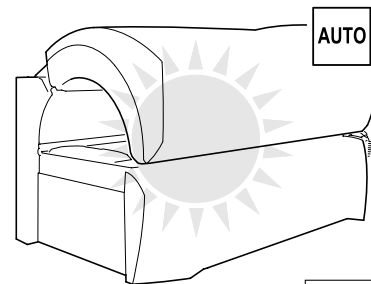

07972 / 0



Automatic mode



1

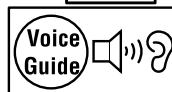
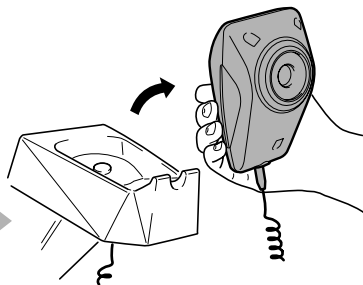
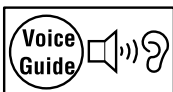

Step one ...

1

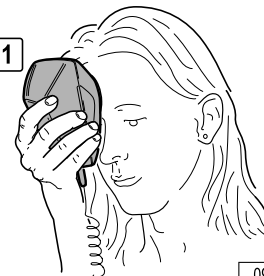

09763 / 0



Start (automatic mode)





2

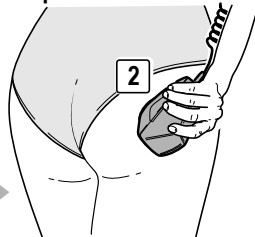

~~Cos-
metics~~

Step two ...

2



Voice
Guide  

Voice
Guide  

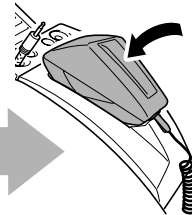

AUTO

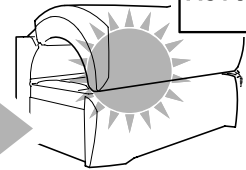

16576 / 0



Regulating the facial tanner



Switching the facial tanners OFF:

- Press button  for two (2) seconds.

Switching the facial tanners on again:

- Press button . It takes approx. one (1) minute until the facial tanners reach their full output.

Adjusting the intensity:

- Press button .
- While the button  flashes, press + or – to adjust the intensity of the facial tanners.

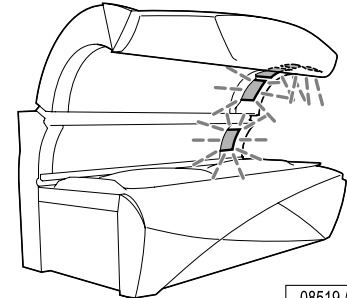

08519 / 0

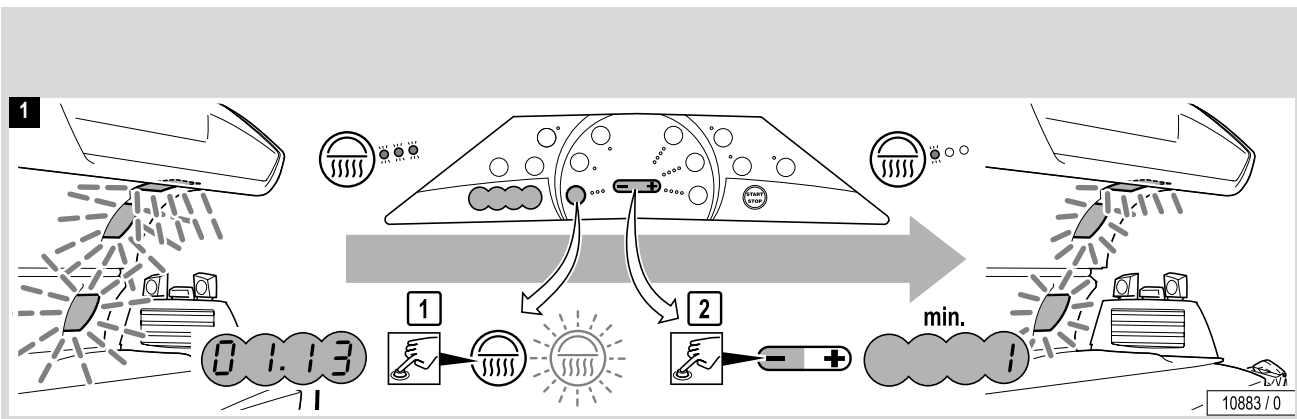

Regulating the facial tanner

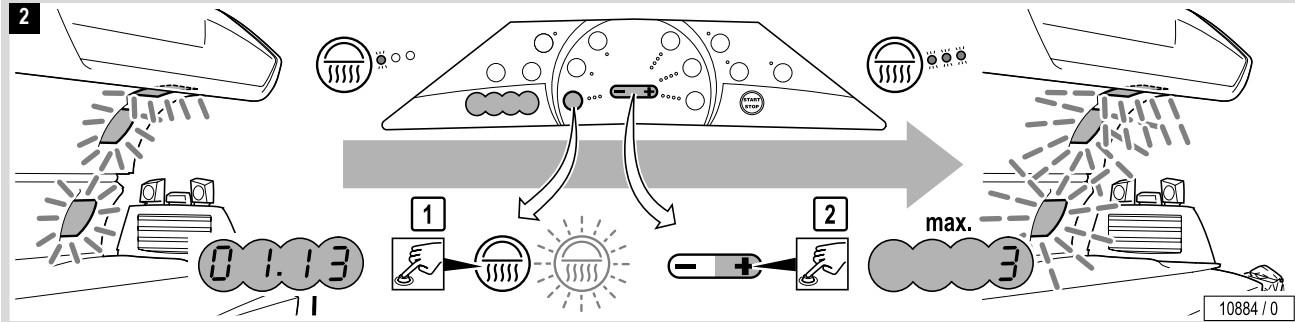

STOP: Press for two (2) seconds.

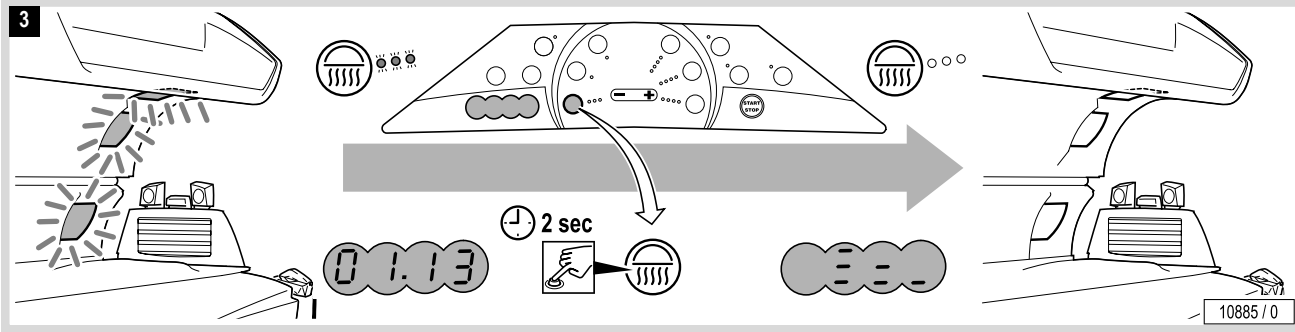

START

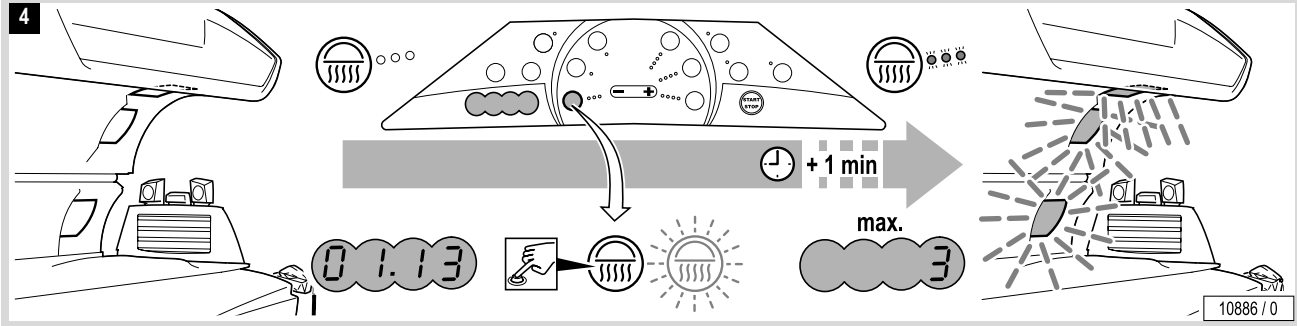

Switching shoulder tanner off and on

Switching the shoulder tanner OFF:

- Press button  for two (2) seconds.

Switching the shoulder tanner on again:

- Press button .

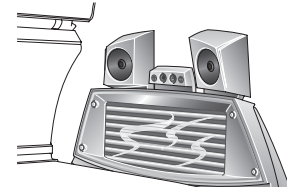

STOP

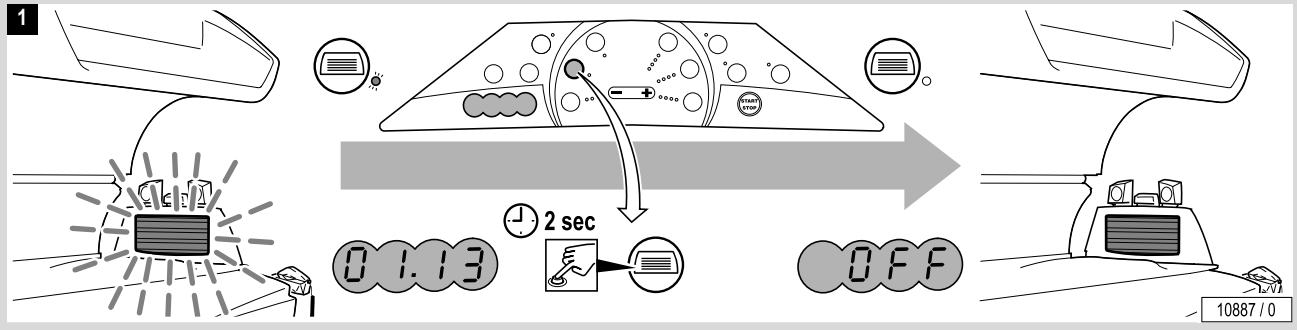

Switching shoulder tanner off and on

START

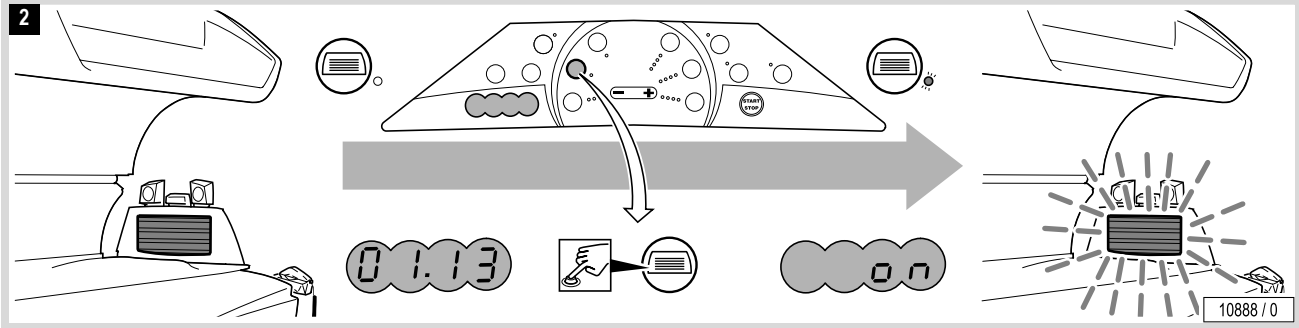

Temptronic – regulating the temperature

During start-up the lightlevel of 8 is active.

- Press button  (Temptronic).

While the button flashes, press the plus or minus button to change the cooling intensity.

Switching Temptronic OFF:

- Press button  for 2 seconds.

Switching Temptronic on again:

- Press button  again. It takes approx. 3 minutes until the cooling effect of the air condition is reestablished.

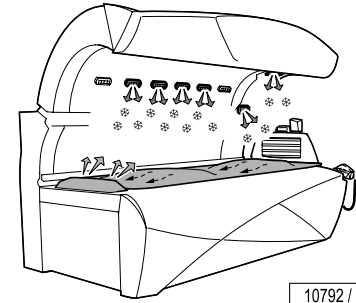

10792 / 0

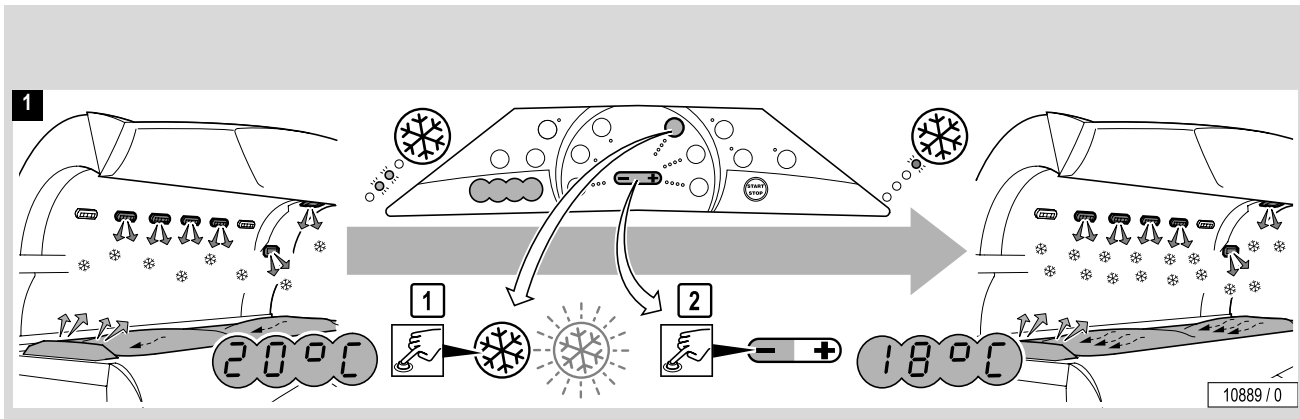

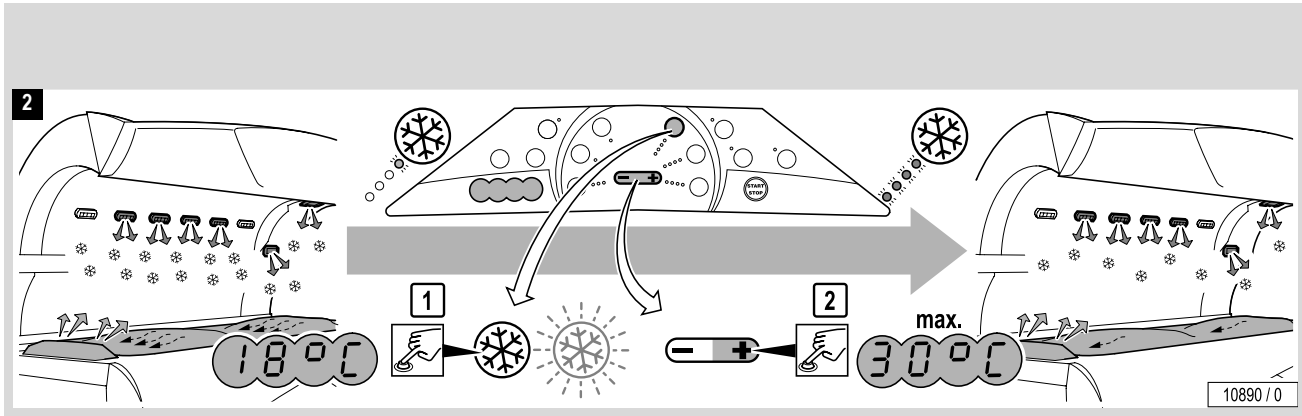

Note:

If the automatic air conditioning (Tempronic) fails, the acrylic glass panel is cooled without adjustment control. In this event, the user can only switch the cooling system on or off.



Regulating facial cooling

- Press button .
- While the button flashes, press the plus or minus button to change the intensity of the air stream.

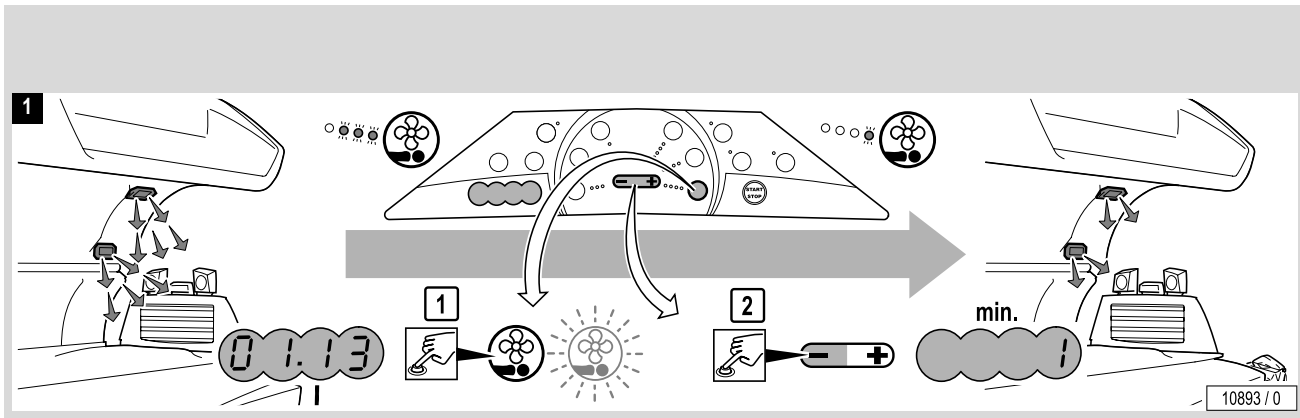
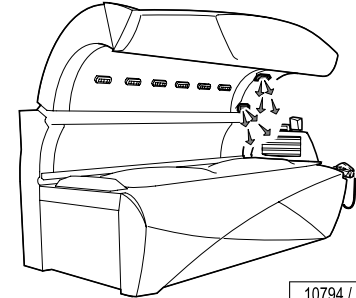

Regulating facial cooling

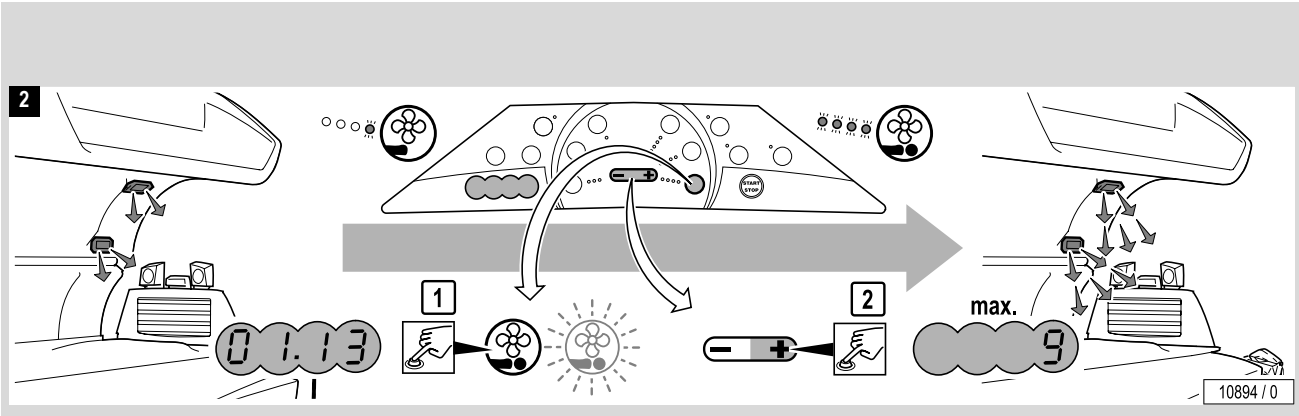

Regulating body cooling

- Press button .
- While the button flashes, press the plus or minus button to change the intensity of the air stream.

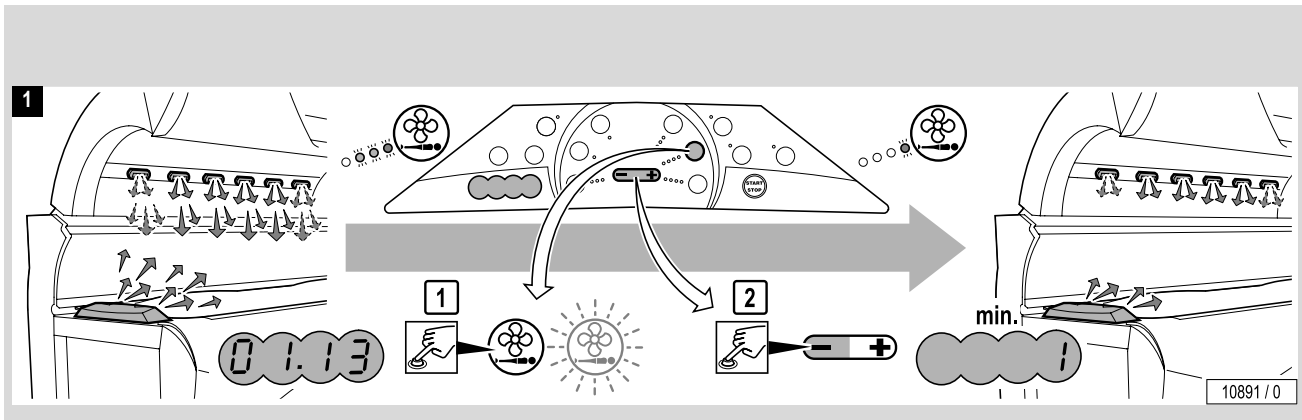
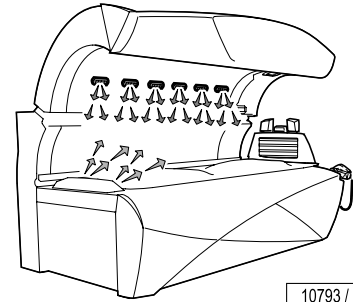

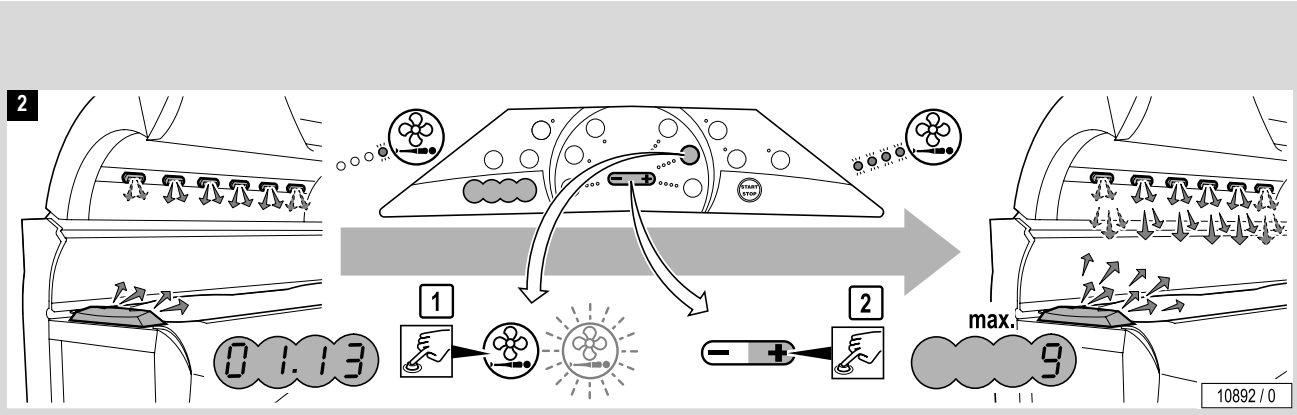

Switching AROMA on and off

The AQUA MIST AROMA system includes an aroma with the scent "Heaven", which is distributed via the head nozzles and in the cabin (no operation possible).

Together with the aroma, AQUA MIST (see Page 45 and 47) is also switched on for the face and body.

Switching Aroma head nozzles on:

- Press button .

Switching Aroma head nozzles OFF:

- Press button  again.

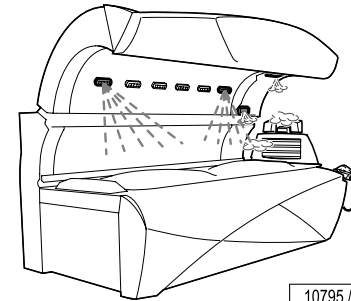

10795 / 0

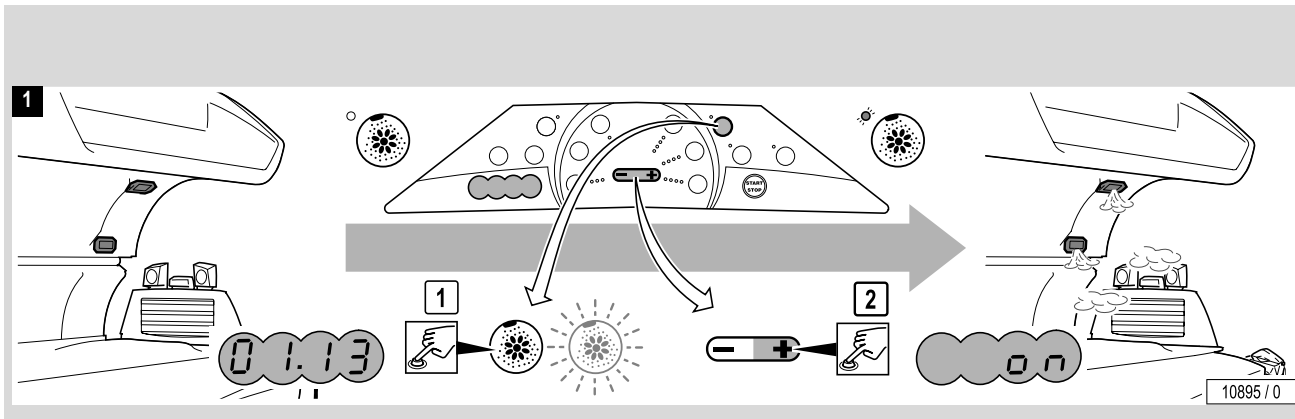

10895 / 0

Switching AROMA on and off

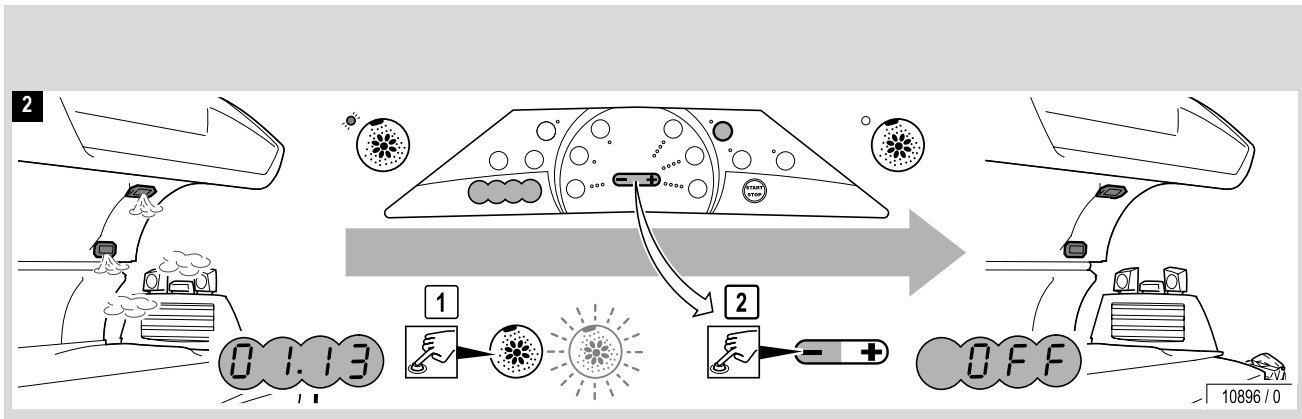

Switching AQUA MIST body nozzle on and off

Switching AQUA MIST body nozzle on:

- Press button .

Switching AQUA MIST body nozzle OFF:

- Press button  again.

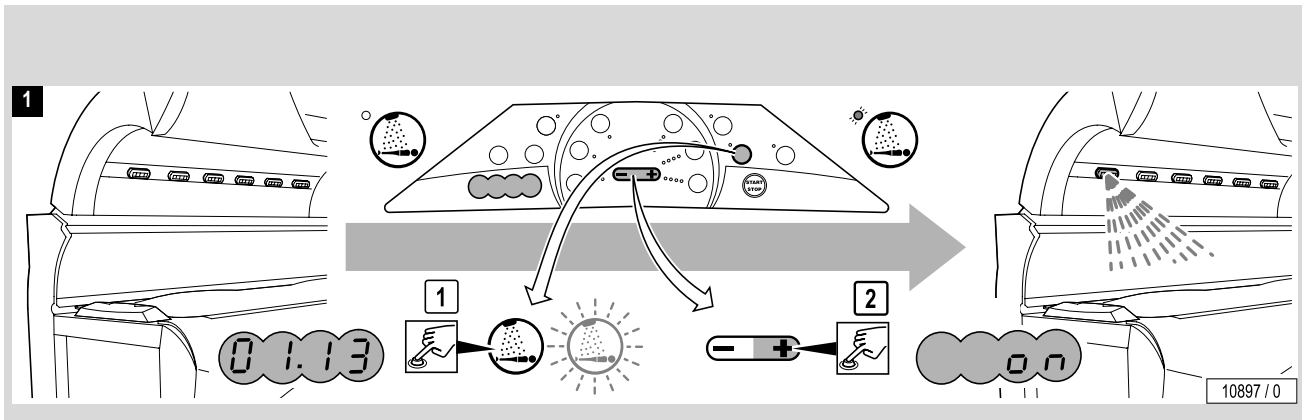
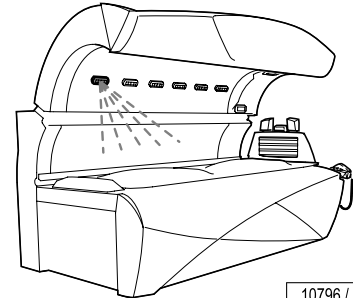

Switching AQUA MIST body nozzle on and off

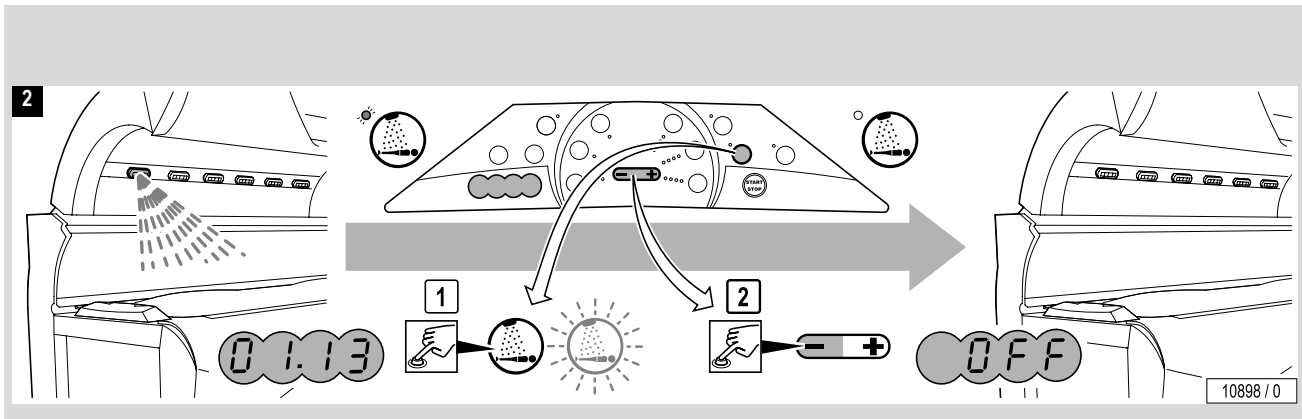

Switching AQUA MIST head nozzle on and off

Switching AQUA MIST head nozzle on:

- Press button .

Switching AQUA MIST head nozzle OFF:

- Press button  again.

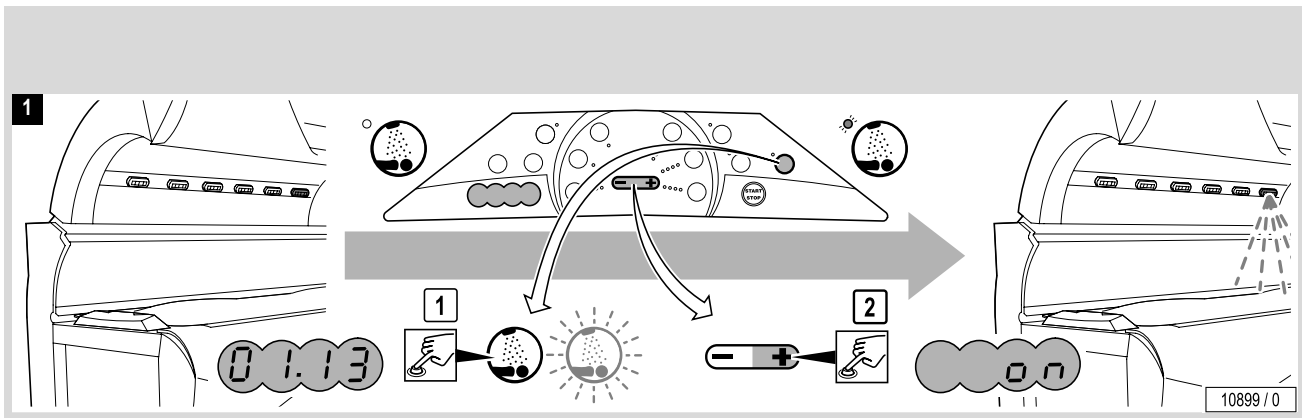
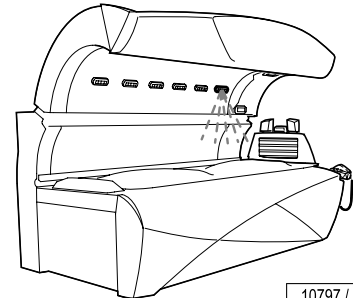

Switching AQUA MIST head nozzle on and off

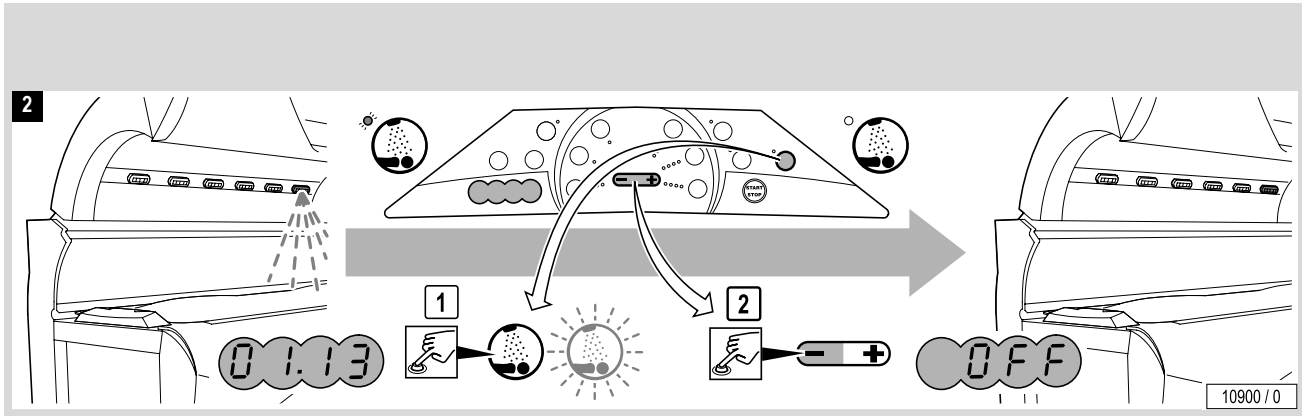

MP3 player connection

Studio customers can connect their own MP3 player to the device when the "Audio System" accessory is available.

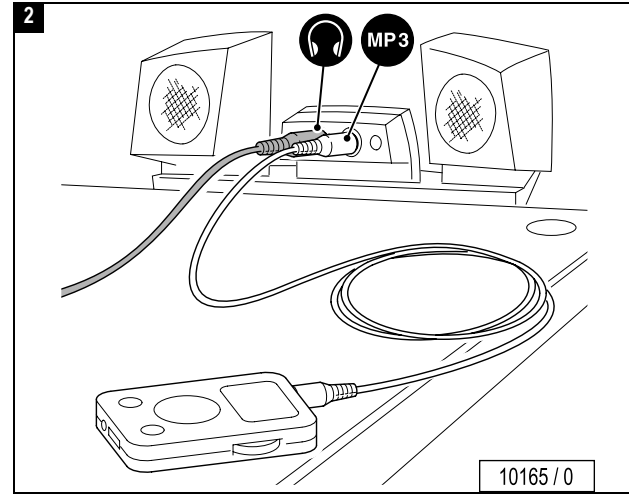
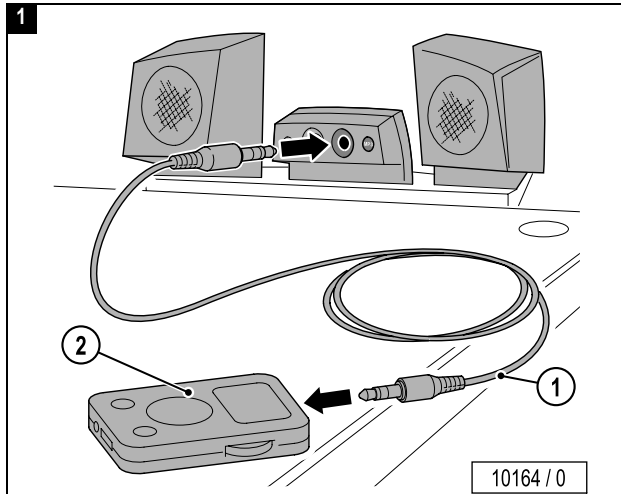

- ① Jack plug (Mat.-Nr. 1001855-..) provided for use by the studio operator (1.5 m / 2 x 3.5 mm stereo jack plug).
- ② MP3 player connection: refer to the manufacturer's documentation.

Loud music might disturb other studio users!

- Use headphones whenever necessary.

...



Caution!

The heat might damage your MP3 player.

- Do not position the unit so that it receives direct tanning radiation.

Cable may be torn off, connectors may be damaged.

- Do not pull on cable when unplugging MP3 player.

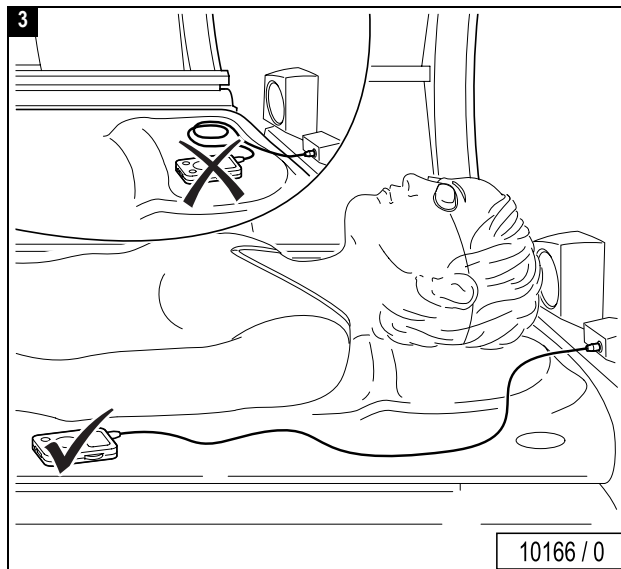

Voice Guide

Voice Guide gives acoustic guidance when operating the device and is only available in conjunction with the audio system.

Voice Guide is activated by default during both stand-by and a tanning session.

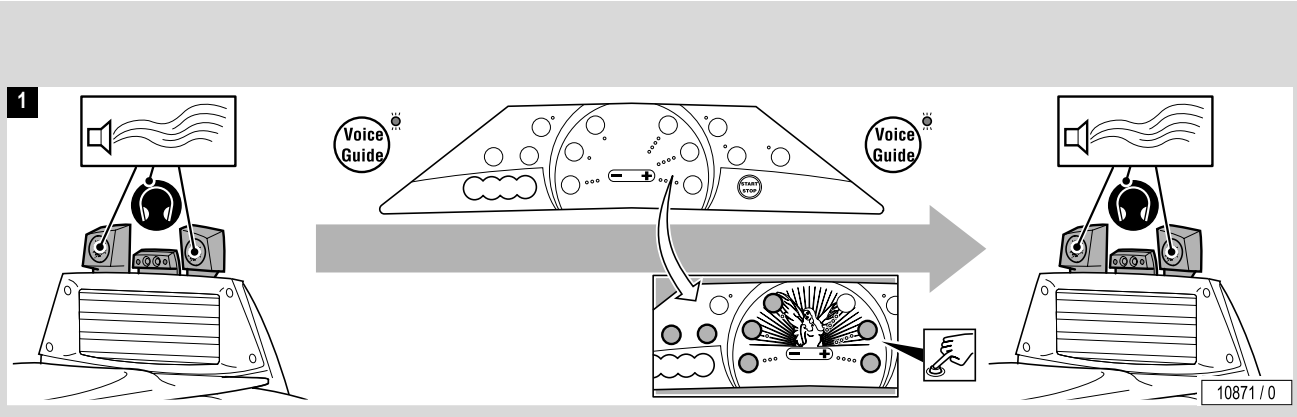
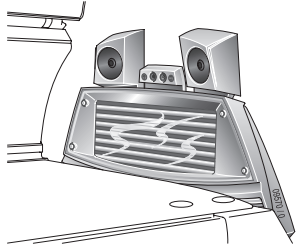

STOP

2

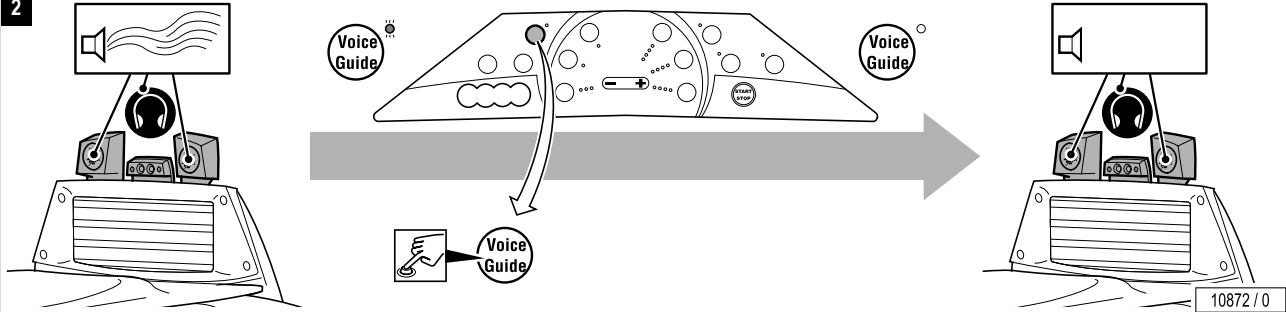

START

3

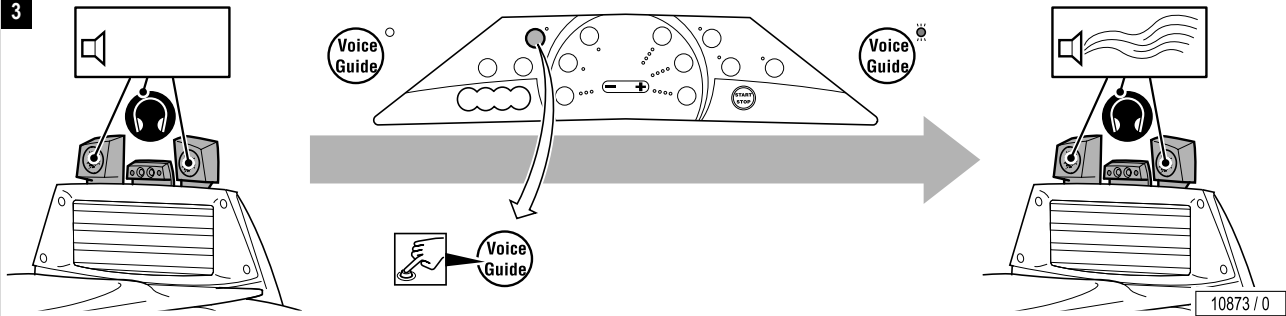

Listening to Info texts

When you press the **INFO** button, general texts on tanning are played.

- Press button **INFO** for 5 seconds.
- While the button flashes, press the plus or minus button to change between info tracks.

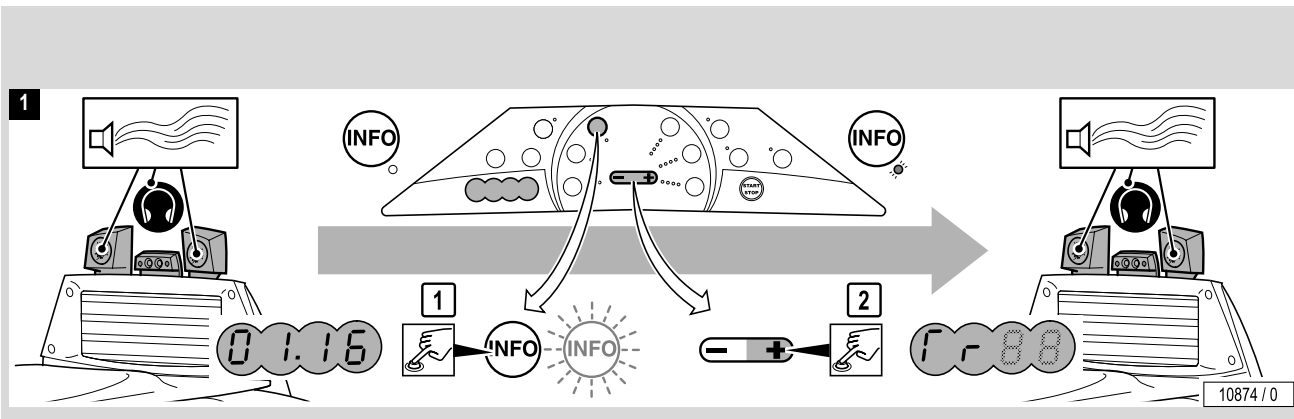
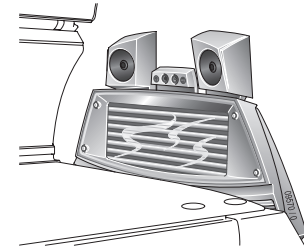

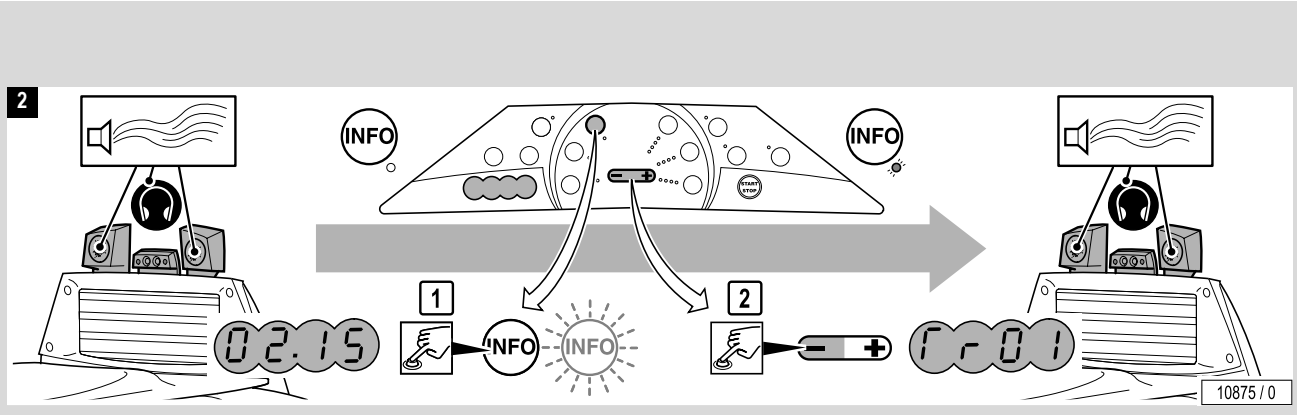

Selecting the audio system (channel)

I.CH (internal): SD card "music"

E.CH (external): externally connected systems (e.g. CD-player)

P.3: MP3 player

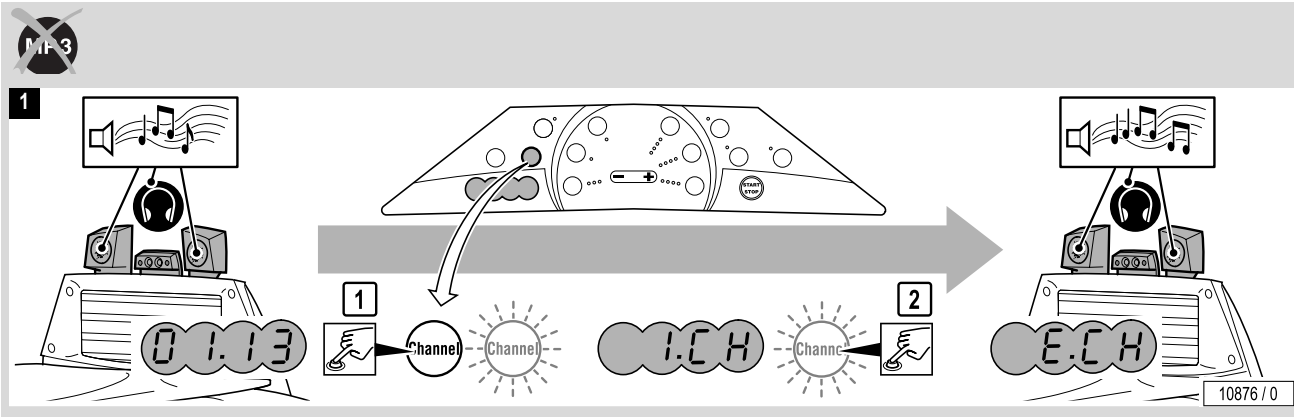
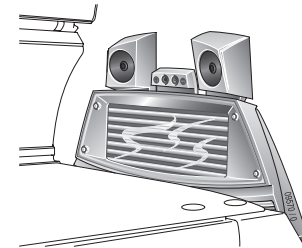

Selecting the audio system (channel)

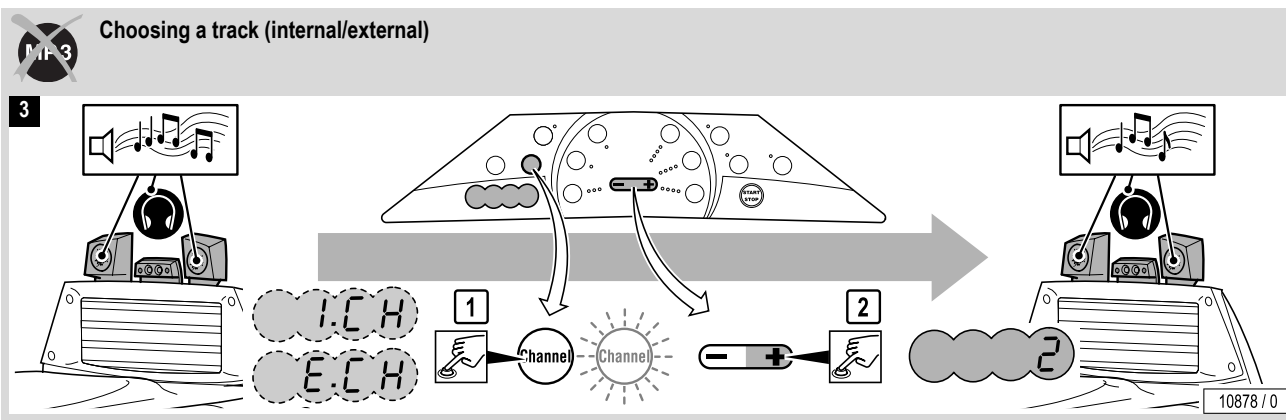
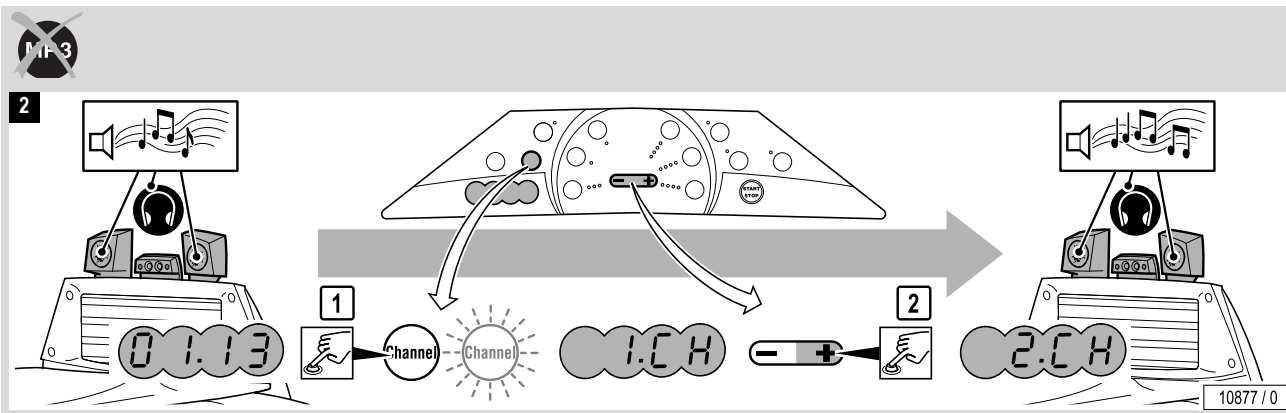

Selecting the audio system (channel)

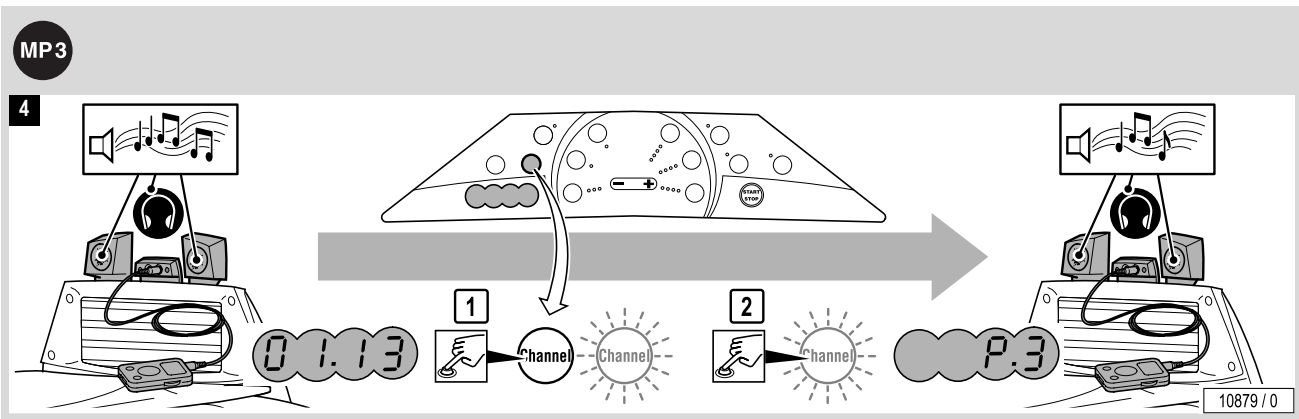

Adjusting the volume and switching-off the audio systems



Risk of hearing loss!

- With time, the human ear becomes accustomed to high sound levels.
- The higher you adjust the volume, the quicker the hearing can be damaged.
- The use of ear pieces and headphones at high volume can lead to permanent hearing loss.

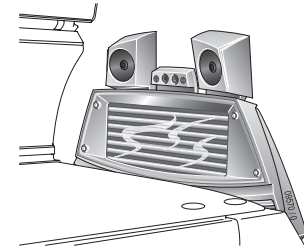

Maximum

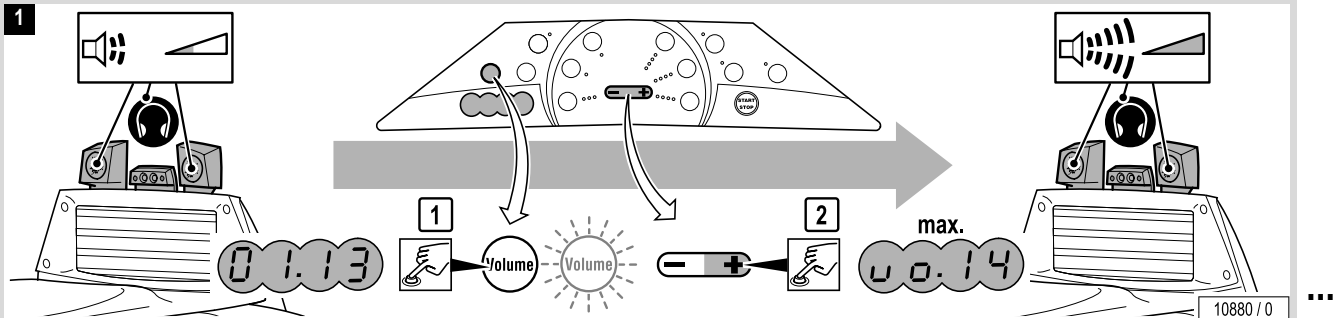

Adjusting the volume and switching-off the audio systems

Minimum

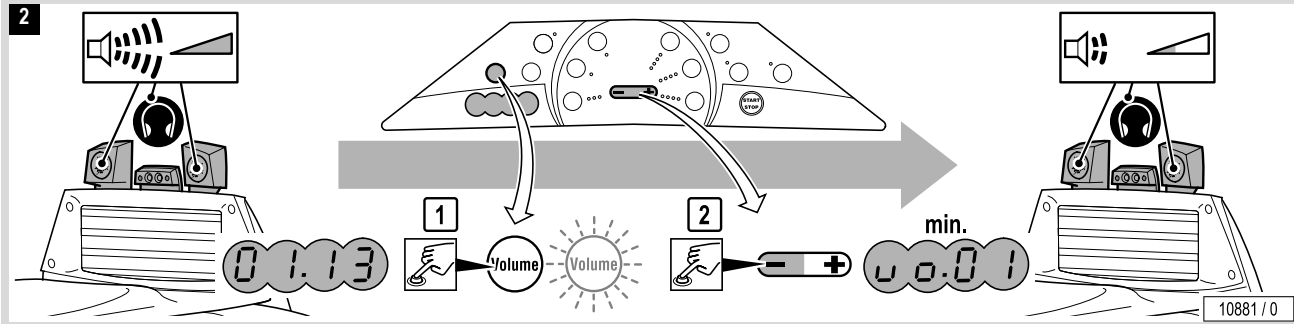

OFF

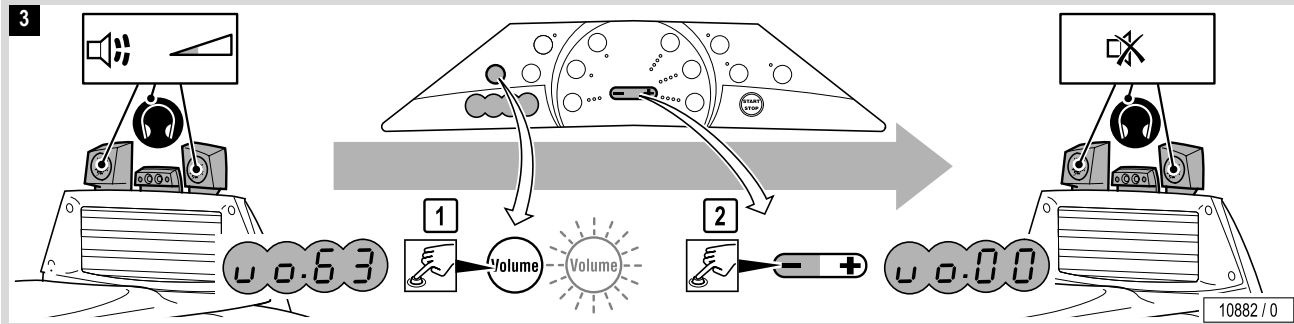

Running time of accent lights

The accent lights are automatically switched on at the end of the tanning session after the set operating time and are switched off again at the beginning of the next tanning session.

The running time of the accent lights in the Standby mode can be changed with the presettings – see separate instructions.



Standby

1

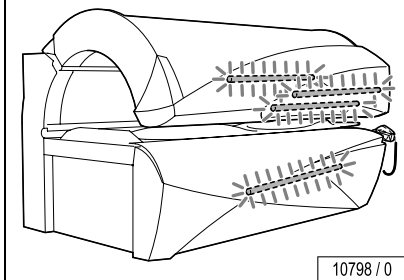

2

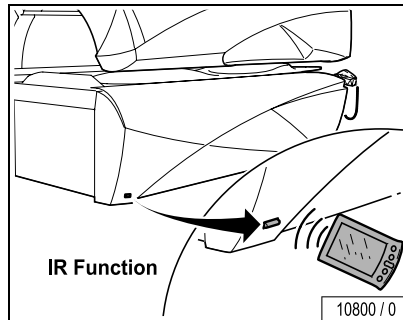
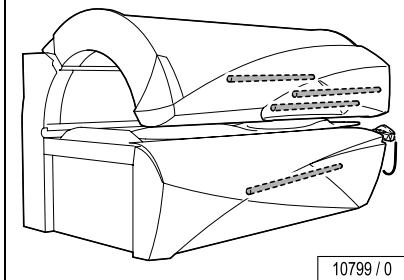

See separate instructions "Presettings", Order no. 1001971



Safety information for maintenance and care



Extreme danger! High voltage!

During maintenance work there is a risk of touching live parts and receiving a fatal electric shock.

- Disconnect device from power supply before opening – also see Page 63.
- Do not reach behind covers and do not open the device with the device switched on.
- Refit any safety devices (e.g. switches) after the work has been completed.

Maintenance and care play a major role in deciding whether the device meets the requirements placed on it in a satisfactory manner. The compliance with the specified maintenance intervals and the careful conducting of the maintenance and care work are therefore absolutely necessary – see Page 69.

The current operating hours of the parts requiring maintenance can be displayed in the Presetting mode – see separate instructions “Presettings”, Order no. 1001971.



Risk of burning!

When changing the UV low pressure lamps, the enclosed chip cards must always be used! The UV low pressure lamps can only be operated at the correct power if the lamp set and chip cards are exchanged simultaneously.

If the old chip cards are left in the unit, the new lamp set is operated at too high power and the user may suffer heavy burns!



Danger of burns!

Only use the specified **genuine UV lamps and filter panels!**

Using other UV lamps leads to modified radiation. This could potentially result in severe burns to the user!

The use of other UV lamps and filter panels invalidates **CE conformity** and the **GS approval mark!**



CAUTION!

Only use **genuine** spare parts of the same type!

The use of other parts may limit or void your manufacturer's warranty!

Any liability is excluded in case of damage or injury proven to be the result of the use of non-genuine spare parts.



...



Fire hazard!

High-pressure lamps that have not been approved by Ergoline can explode. Hot lamp components can set other components on fire. People can be killed or severely injured due to smoke inhalation and fire.

- Only fit high-pressure lamps recommended by Ergoline.
- Clean the inside of the tanning device regularly. Dust-particles are combustible!

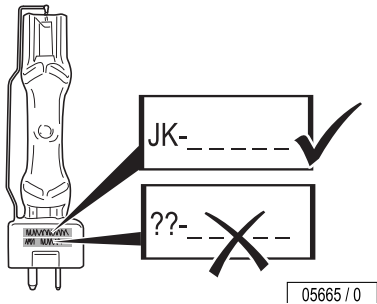

Power Off device and secure against being switched on again



Extreme danger!

If work is to be performed on the devices, they must be powered off. That means that all live lines must be switched off. Switching off the device alone is insufficient, as certain points may remain energized. Therefore, switch off and lockout circuit breakers before performing any work.

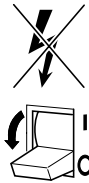

04049 / 0

A prohibition sign with the text: "Work in progress!"

- "Place:"
- "Sign may only be removed by:" must always be securely mounted immediately.



01511 / 1



Extreme danger!

Severe accidents can occur if the device is mistakenly switched on again. Immediately after powering off, secure all switches or fuses used for power against being switched on again.

- A strip of adhesive tape with the wording "DANGER do not switch ON!" may be applied over the actuation levers of circuit breakers which cannot be removed.

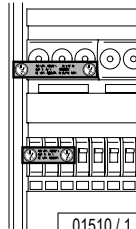

01510 / 1



Extreme danger!

Prohibition signs must not be hung on or touch live parts.



...

Malfunctions

The display shows error codes¹⁾ to make it easier to localize the cause of the problem.

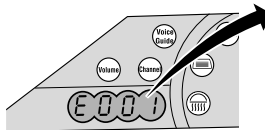

Fehlercode	Störung/Fehlerbeschreibung	Abhilfe
E 0 0 1	Kondensatbehälter voll (Fehleranzeige nur möglich bei Original-Kondensatbehälter.)	Kondensatbehälter leeren
E 0 0 2	Störung Kondensatpumpe	
E 0 0 3	Überdruckschalter Klimagerät (Gerätekühlung)	
E 0 0 4	Druckwächter +B24 Klimadruck überschritten	
E 0 0 5	Temperaturfühler Climatronic (Klimagerät)	
E 0 0 6	Temperaturfühler Climatronic (Klimagerät)	
E 0 0 7	Warnung Betriebsstunden Filter Klimagerät überschritten	
E 0 1 0	Temperaturbegrenzer Gesichtsbürste	

10389 / 0

- If a malfunction occurs, the error code flashes in the display.
- If several malfunctions occur, the error messages are displayed alternately.
- The fault remedy is acknowledged by holding down the **START/STOP** button.
- If the problem cannot be remedied, inform Customer Service – see Page 2.

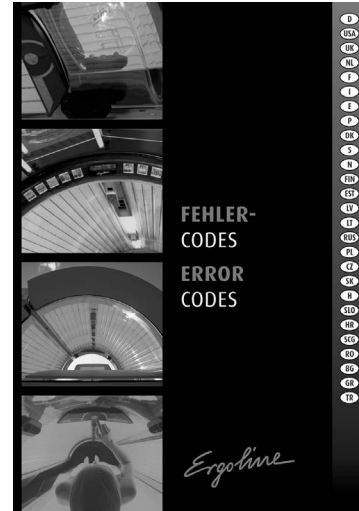

800751

10391 / 0



1) See separate instructions "Error Codes", Order no. 800751



WARNING!

WARNING – risk of infection!

Infections can be transferred through skin contact.

All items/equipment components, with which the user can come into contact during tanning, must be disinfected after every tanning session:

- Sunbed acrylic
- Headrest
- Handles and control panel
- Adjustable air nozzles
- Protective goggles
- MP3 cable
- Sensor and base station

For fast, hygienic proper cleaning, use a specially developed fast disinfectant cleaner.

Note:

To ensure thorough disinfection, always adhere to the reaction time specified for the disinfectant.

Follow the manufacturer's instructions for use.

Acrylic glass surfaces



CAUTION!

Do not rub with a dry cloth – danger of scratching!

For fast, hygienic proper cleaning of acrylic glass surfaces, use a specially developed fast disinfectant cleaner.

Other cleaning agents, especially concentrated disinfectants or solvents (e.g. Lysoform, ethyl alcohol or other liquids containing alcohol) must never be used for cleaning.

Failure to observe this voids all warranty claims.



Plastic surfaces

For cleaning the other plastic surfaces, it is best to use warm water and a leather cloth. Never use aggressive cleaning agents containing alcohol or essential oils. These may lead, in the long run, to damage not covered by the warranty.

During cleaning, a slight discoloration of the leather cloth by the rubber seals must be expected for production-related reasons.



Note:

Prevent damage to plastic surfaces. Remove rings, watches, bracelets etc. before the start of cleaning work.

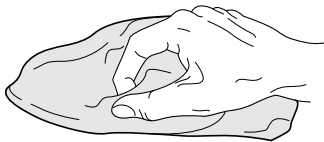

02756 / 0

Cleaning filter panes and lamps

The UV high-pressure lamps fitted are broadband radiators which can be operated at different outputs (approx. 240-520 W).



UV low pressure lamps: Clean with water only (damp cloth)

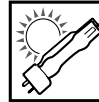

UV high pressure lamps: Clean jackets with methylated spirits if necessary.

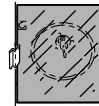

Filter panes: Clean with water only (damp cloth)



Maintenance

AQUA MIST

The AQUA MIST function sprays a fine mist of AQUA SOLAR WITH SKIN+ ADDITIVE into the tanning chamber.



Health hazard for your customers!

Water contaminated with bacteria can cause skin rashes and other allergic reactions in sunbed users.



– Do not, therefore, fill the AQUA MIST canister with tap water or other liquids.



– Only replace the AQUA MIST canister with a genuine canister.



– Do not add any leftovers from the old canister to the new canister.

– Ensure that the specified maximum temperature is not exceeded during transport and storage.

– Note the expiry date on the canister.

AROMA

The AQUA MIST AROMA system also includes a fragrance „heaven“, which is distributed via the head nozzles.

The aroma “heaven” is distributed in the cabin.



Note:

Alternatively further fragrances are available from Global Service USA (see page 2).

Acrylic covers

The acrylic covers for the sunbeds are produced of acrylic glass developed especially for this application. The acrylics used are characterized by a particularly high UV permeability and resistance, as well as an easy-care, hygienic surface that is gentle to the skin.

The acrylic covers are formed to sunbed-specific shapes in a technically complex production process. Despite state-of-the-art production know-how, the presence of minor spots, air bubbles or streaks in the acrylic panels is unavoidable. In addition, hairline cracks can occur on the acrylic glass panel during operation.

These occurrences are material-dependent and are unavoidable in processing, however have no significant effect on the utility value and can therefore not be recognized as defects.



Caution!

Cosmetics or sun screen products must be removed prior to tanning as they can cause damage (e.g. fine cracks on the surface) when used continuously.



Cleaning and maintenance intervals

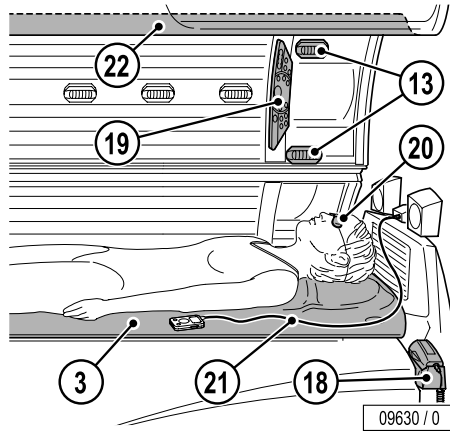

09630 / 0

After each tanning



③

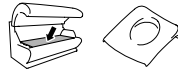

☞ 66

⑬

Adjustable air nozzles

☞ 66

⑳



WARNING!

WARNING – risk of eye irritation!
Protective goggles may only be cleaned with an approved disinfectant.

☞ 66



Schmerler 2255
Ergoline 84592



☞ 66

⑱



☞ 66

㉑

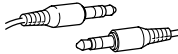

1001855

☞ 66

㉒



☞ 66

⑱



☞ 76



Confirm cleaning by pressing the START/STOP button (when the follow-up time of the fan in the device has finished).



...

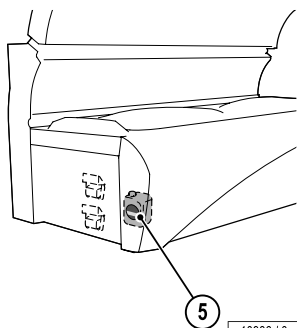

10986 / 0

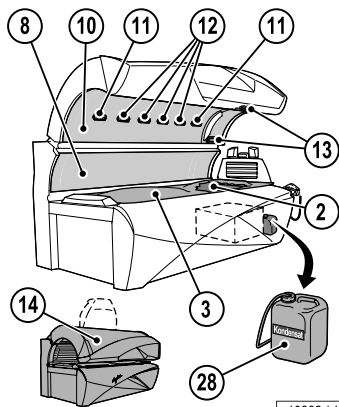

10802 / 1

Intervalle / Intervals¹⁾

⑤



Intervalle, see
"PRODUCT
INFORMATION
AQUA SYSTEM"
(order no.: ▲
801610-..).



② - ⑭

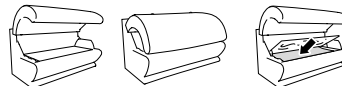

➔ 66

⑤



➔ 110

⑳



Empty



➔ 107

...

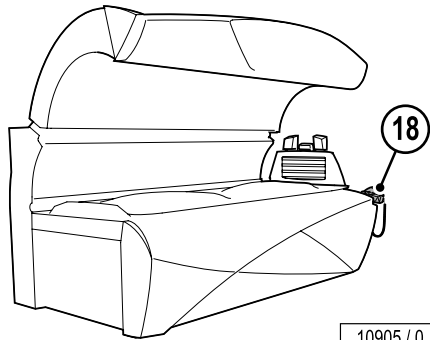
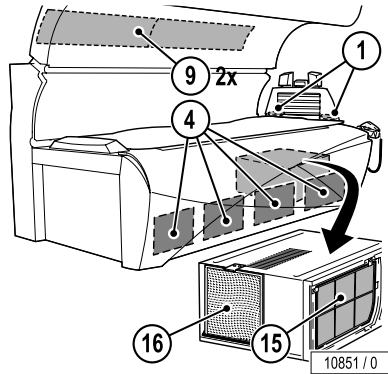

50 h

④



🗨 102

⑨



🗨 107

①



🗨 105

⑮



🗨 107

⑯



🗨 107

30 days

⑱



Recalibrate the sensor every 30 working days, so that the user's skin type can be determined reliably and the UV lamp output is optimised for the skin type.
Calibration: see separate instructions "Kalibrieren / Calibration" (Order no.: 1006011-..)



...

300 h 

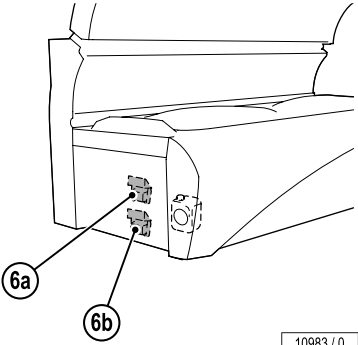

6a
6b

10983 / 0

6 a)
b)

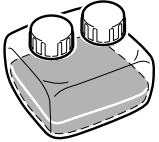

 110

...



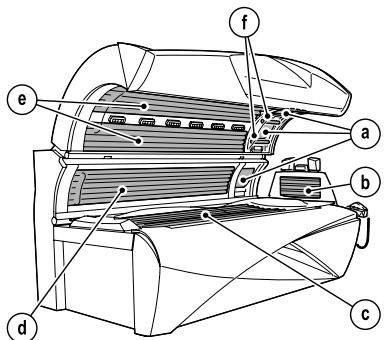

10804 / 0

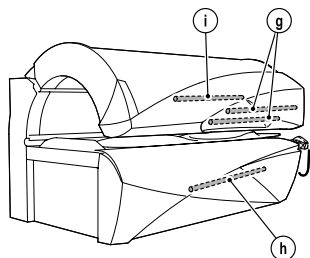



10849 / 0

500 h 

a)				91, 94
b), f)				81, 87

1000 h 

c)				87
d)				87
e)				94

1000 h 

b), f)				81, 87
g), h), i)				89, 98, 100



...

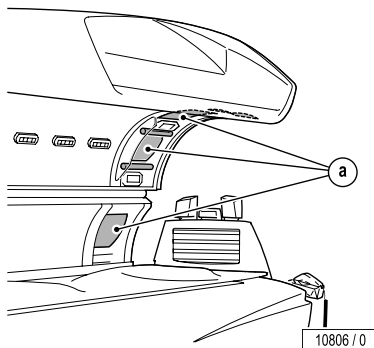
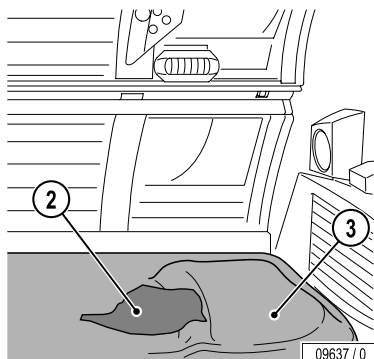

1500 h



③

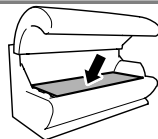

3000 h

②

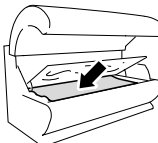

a)



91



Relamping / maintenance instructions

It is imperative that you, the owner and/or operator, check all components for any signs of wear which may occur through normal use.

Observe the cleaning and maintenance schedule specified in the maintenance table on Page 69 to 76.

Only replace UV low-pressure lamps with the original lamp type or with compatible lamps.

Only replace UV high-pressure lamps with the original lamp type or with compatible lamps.

Should you require any assistance or need additional information, please call Global Service USA at 800 445 0624, Monday through Friday 7:00 a.m. - 7:00 p.m. CT, Saturday 8:00 a.m. to 3:00 p.m.



CAUTION – Damage due to improper maintenance!

Improper maintenance can cause the device to be damaged or to become unusable.

- Always comply with the specified maintenance intervals.
- Follow the cleaning instructions.
- If the maintenance intervals for the UV lamps are exceeded or incompatible UV lamps are installed, the share of harmful UVB radiation may increase. Sunburn and other skin damage may result.



WARNING!

Danger of burns from hot lamps and device parts!

WARNING! If the tanning device was operated before being switched off and opened, lamps and housing parts may be hot.



- Before replacing lamps or other spare parts, wait until lamps and metal parts of the device have cooled down sufficiently.



Danger of pinching!

When opening and closing the tray, panels and covers, you can pinch your fingers.



Sensor and base station cleaning

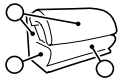

AUTO

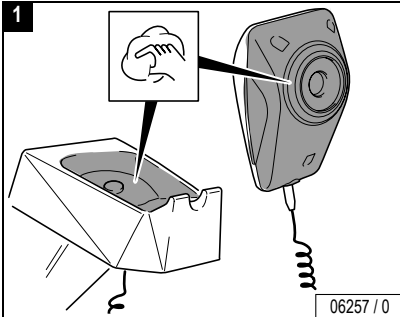
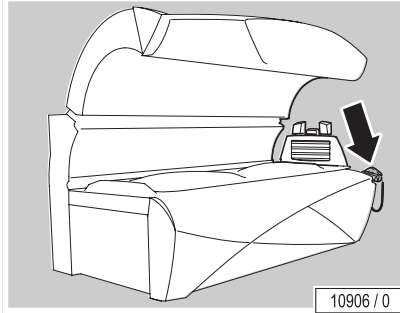

Disinfect sensor and base station after each session with a fast disinfectant cleaner.



Caution!

Do not spray or immerse! Only rub with a damp, soft cloth.



Caution!

Do not rub with a dry cloth – danger of scratching!
Only use a specially developed fast disinfectant cleaner for cleaning the sensor and base station.

For fast, hygienic proper cleaning of acrylic glass surfaces, use a specially developed fast disinfectant cleaner.

Other cleaning agents, especially concentrated disinfectants or solvents (e.g. Lysoform, ethyl alcohol or other liquids containing alcohol) must never be used for cleaning.

Failure to observe this voids all warranty claims.



Inserting the chip card of the new lamp set

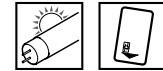

Risk of burning!

When changing the UV low pressure lamps, the enclosed chip cards must always be used! The UV low pressure lamps can only be operated at the correct power if the lamp set and chip cards are exchanged simultaneously.

If the old chip cards are left in the unit, the new lamp set is operated at too high power and the user may suffer heavy burns!

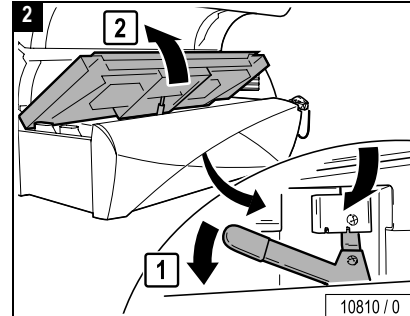
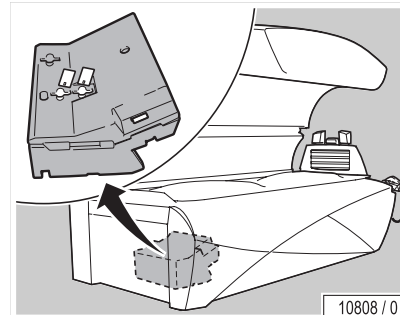
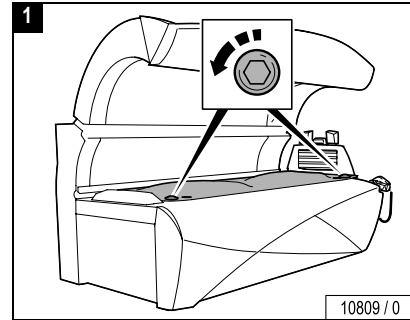
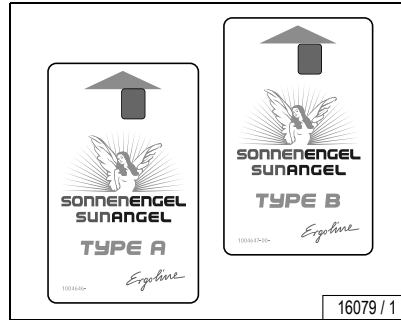
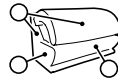

...

Inserting the chip card of the new lamp set

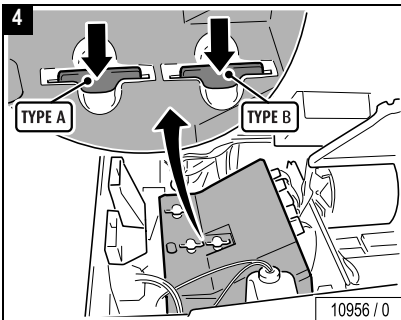
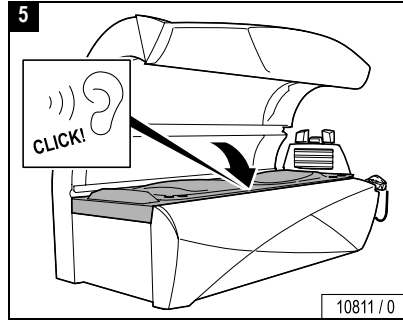
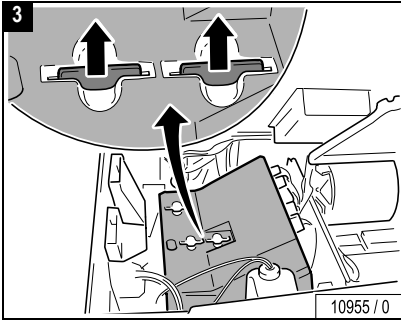

Close:

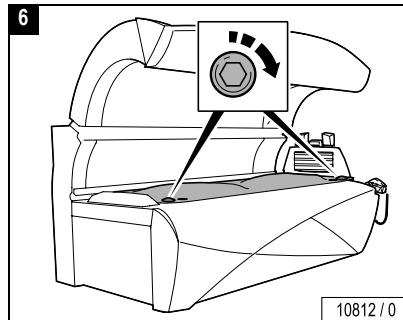

Cleaning/replacing UV low-pressure lamps in the sunbed base

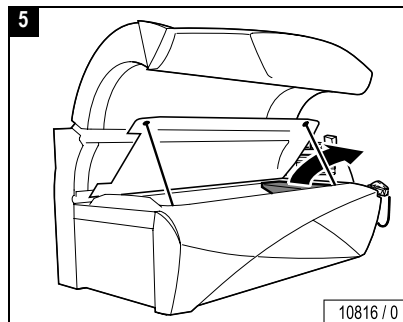
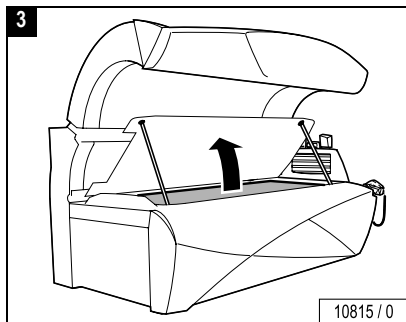
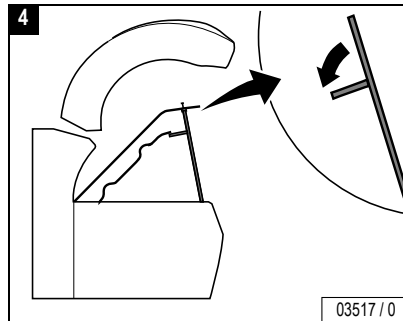
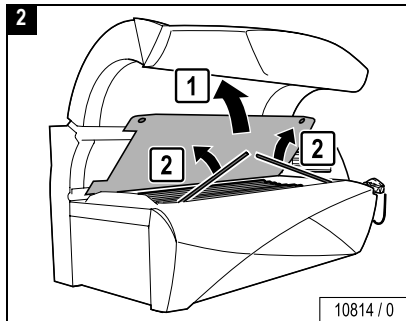
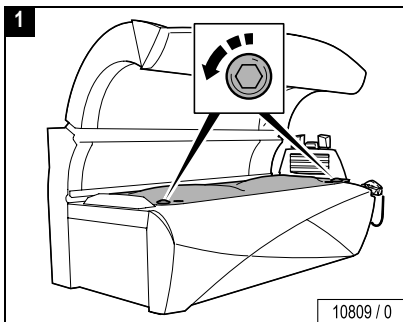
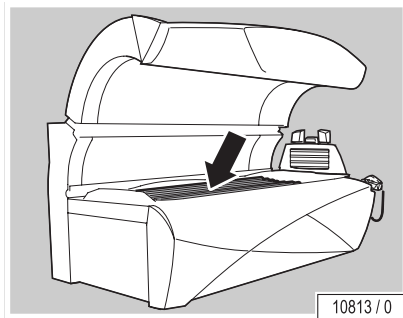
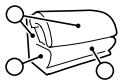

...

Cleaning/replacing UV low-pressure lamps in the sunbed base

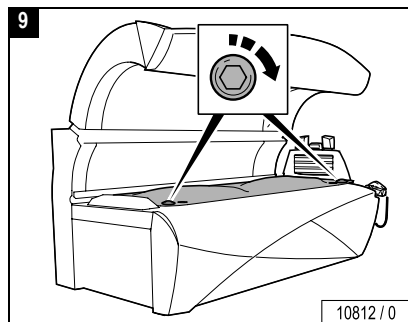
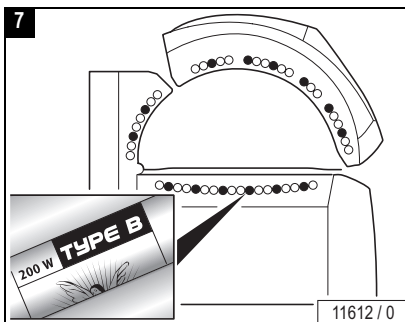
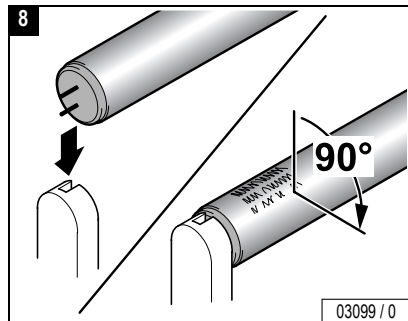
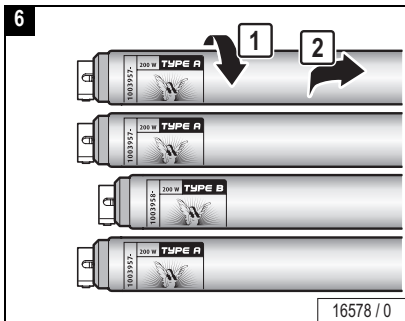

Cleaning/replacing UV low-pressure lamps in the shoulder tanner

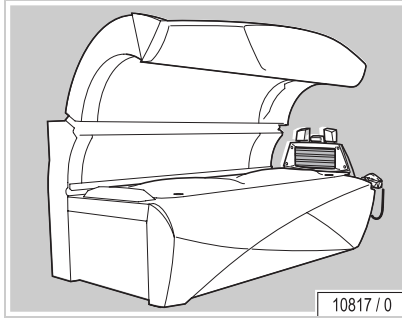
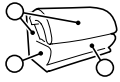

Power Off!

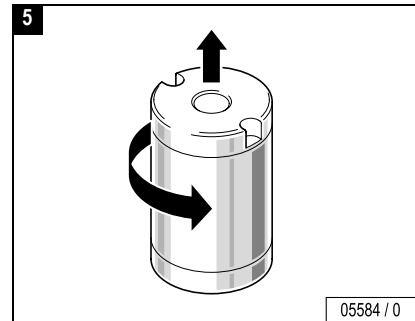
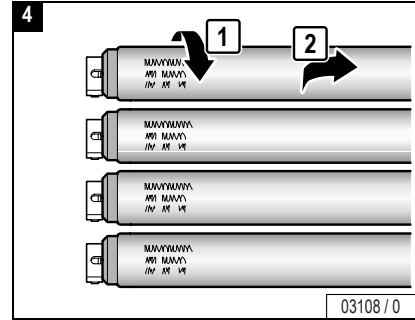
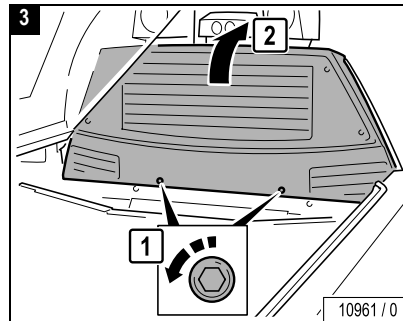
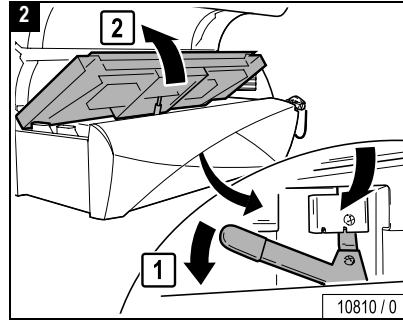
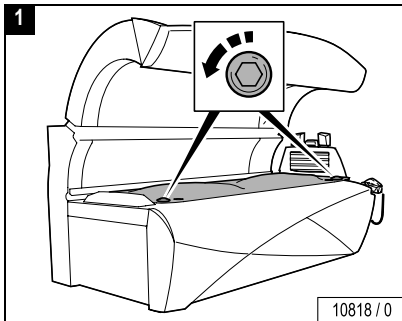

...

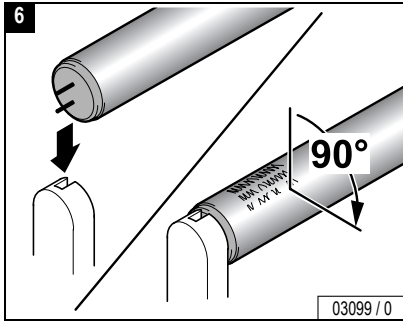

Caution!

Soiling on the panes is burned in by the hot lamps and results in unserviceable panes in the long term.

- Remove fingerprints and other soiling carefully.

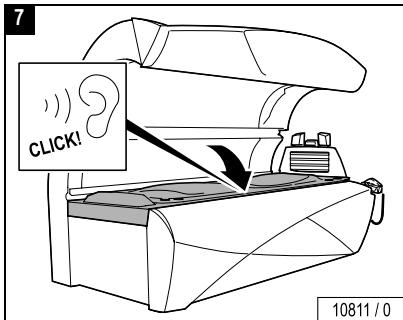

Close:

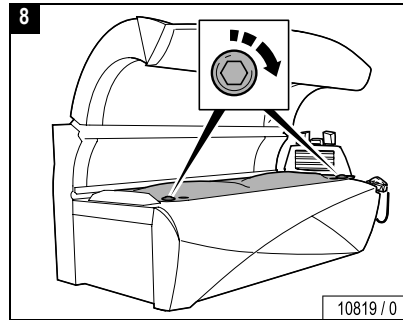

Cleaning/replacing UV low-pressure lamps in the side section

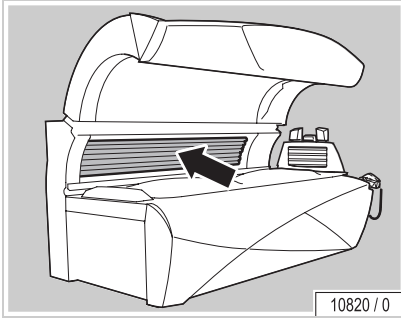
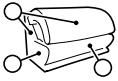

10820 / 0



Power Off!

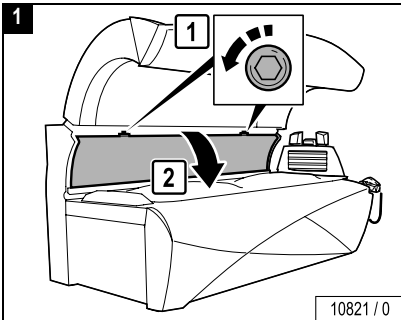

10821 / 0

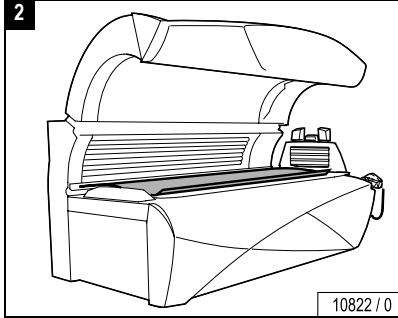

10822 / 0

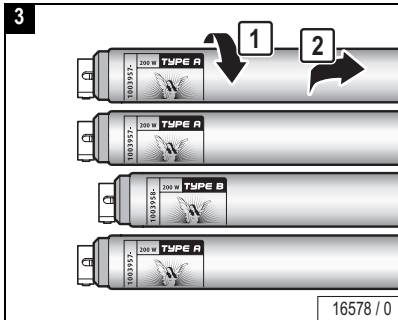

16578 / 0

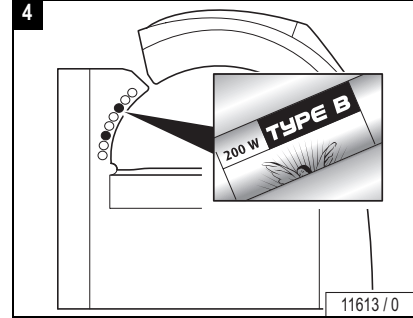

11613 / 0



...

Cleaning/replacing UV low-pressure lamps in the side section

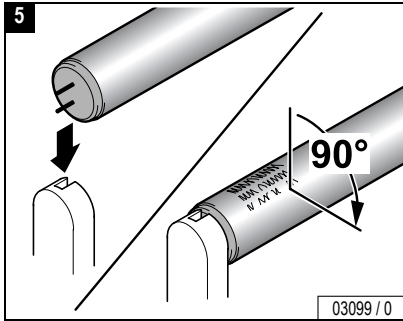

Close:

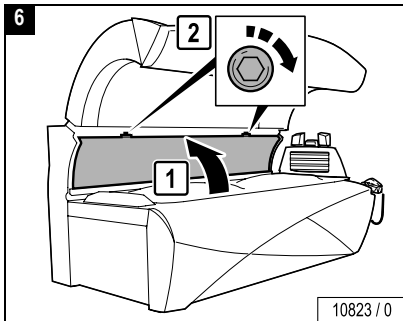

Cleaning/replacing UV low-pressure lamps in the canopy

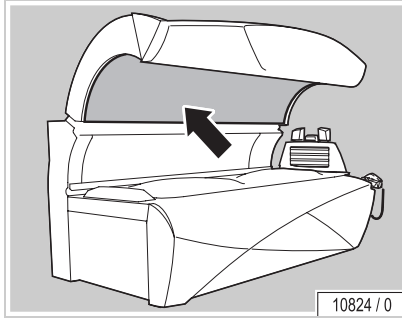
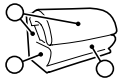

Danger of injury from the canopy panel!

WARNING! The canopy panel is heavy and falls down by itself after unscrewing the 3 screws.

- Support canopy panel.
- Loosen screws in the specified order.



Caution!

Canopy panel may break if allowed to fall or if pressure is exerted on the reverse side of an open canopy. Such failure is not covered by manufacturer's warranty.



Power Off!

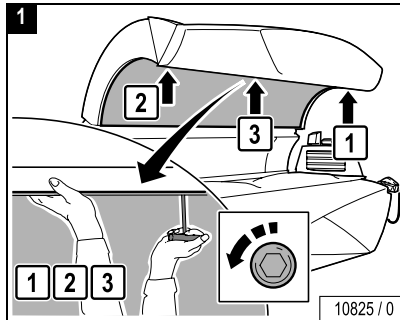

2

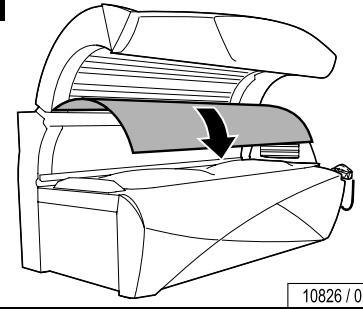

3

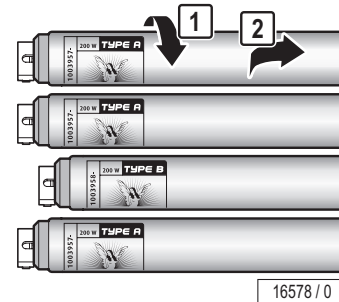

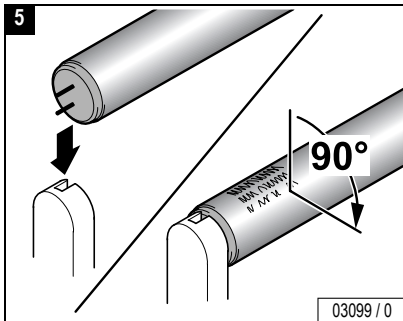
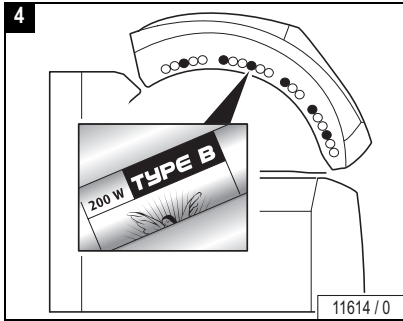

Close:

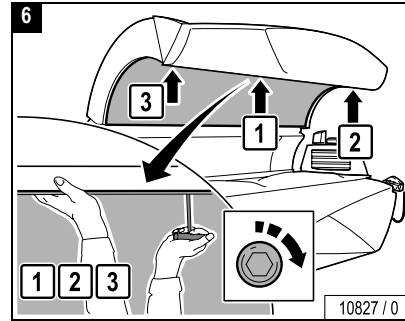

Cleaning/replacing UV low-pressure lamps in the facial tanner

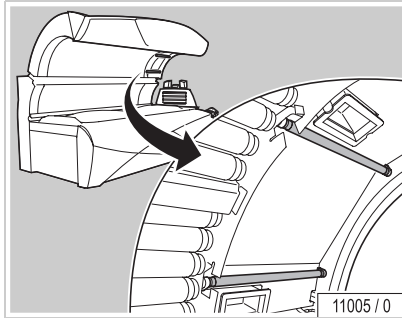
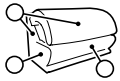

Power Off!

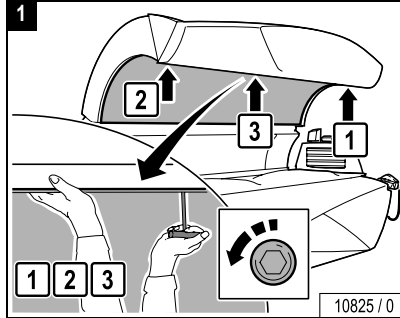

Caution!

Canopy panel may break if allowed to fall or if pressure is exerted on the reverse side of an open canopy. Such failure is not covered by manufacturer's warranty.



Danger of injury from the canopy panel!

WARNING! The canopy panel is heavy and falls down by itself after unscrewing the 3 screws.

- Support canopy panel.
- Loosen screws in the specified order.

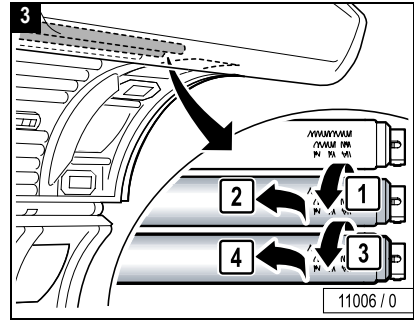
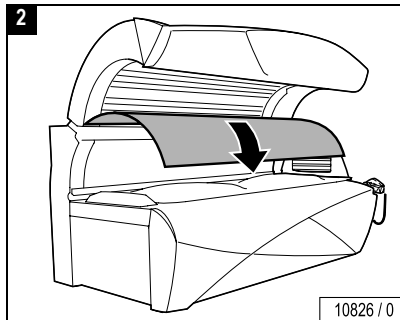

...

Cleaning/replacing UV low-pressure lamps in the facial tanner

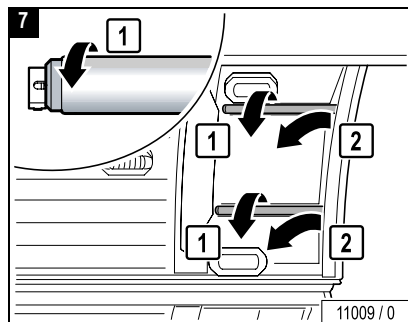
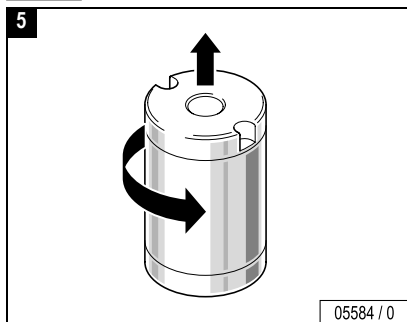
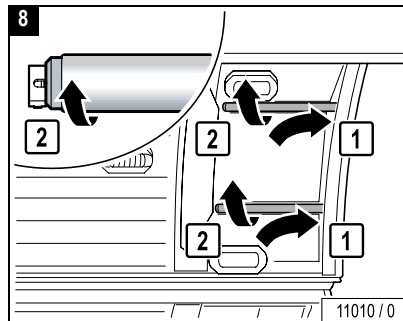
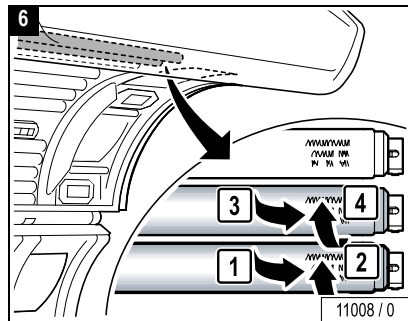
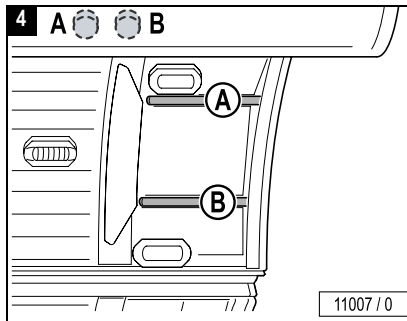

Close:

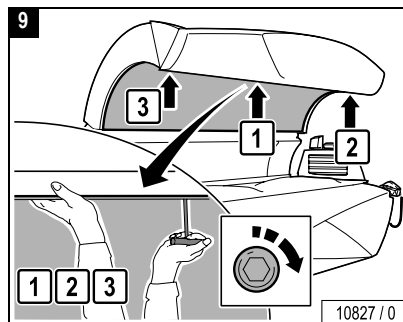

Cleaning/replacing interior lighting

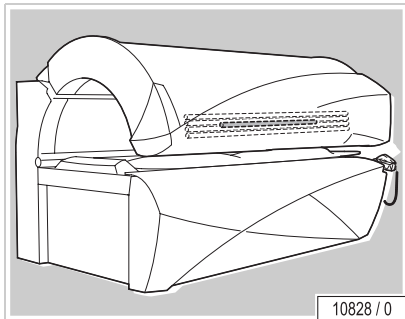
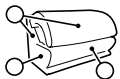

Danger of injury from the canopy panel!

WARNING! The canopy panel is heavy and falls down by itself after unscrewing the 3 screws.

- Support canopy panel.
- Loosen screws in the specified order.



Caution!

Canopy panel may break if allowed to fall or if pressure is exerted on the reverse side of an open canopy. Such failure is not covered by manufacturer's warranty.



Power Off!

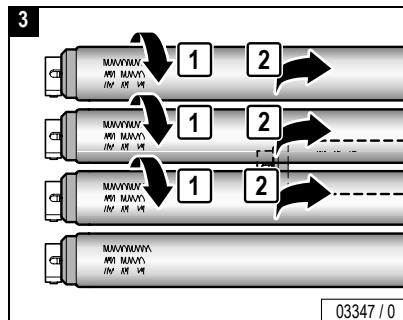
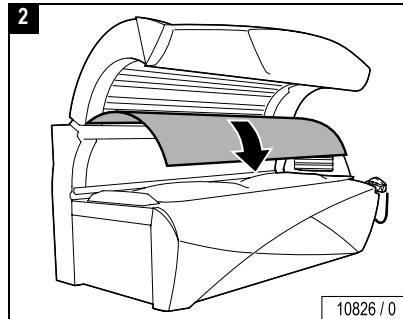
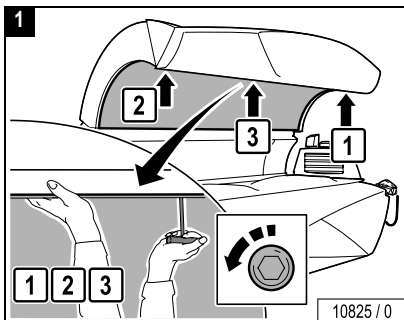

...

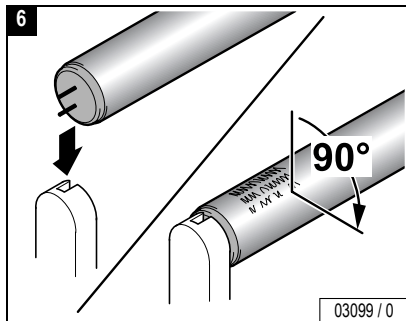
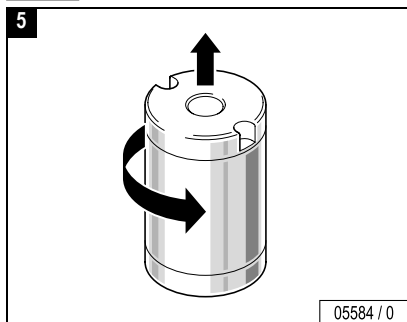
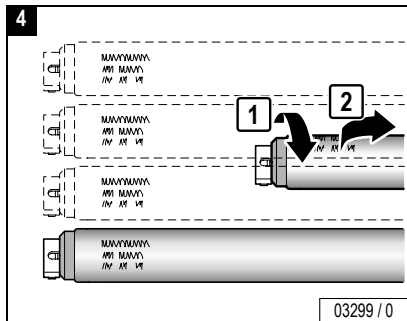

Close:

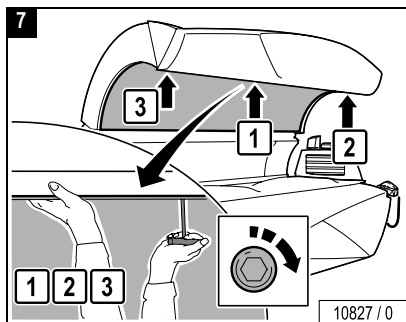

Cleaning/replacing UV high-pressure lamps and filter panels in the side section

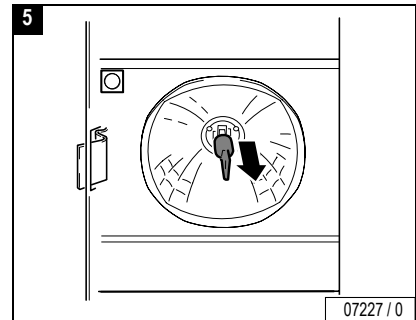
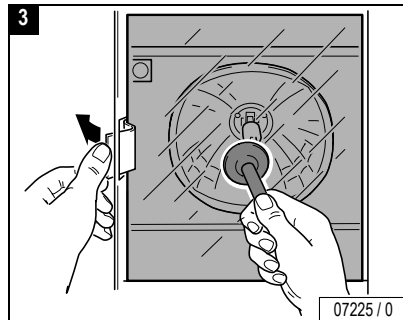
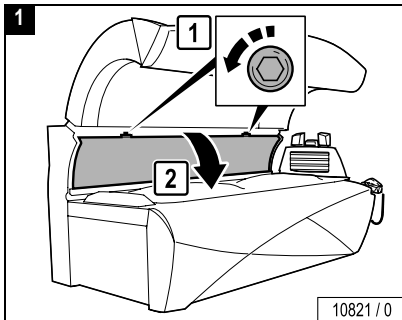
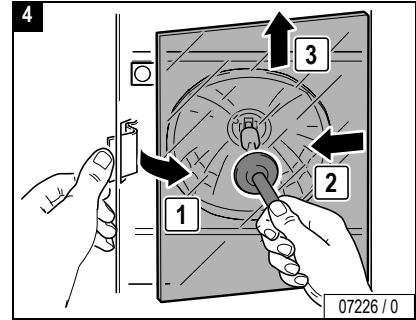
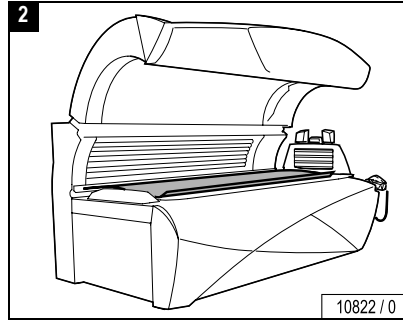
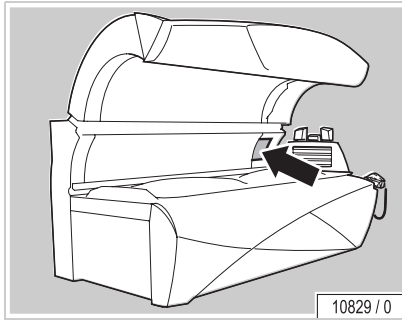
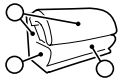

...

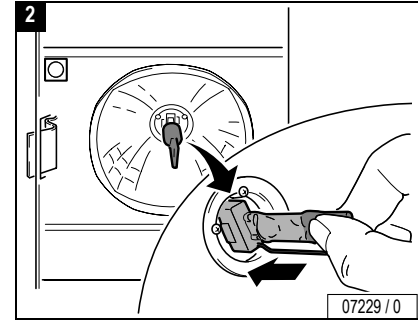
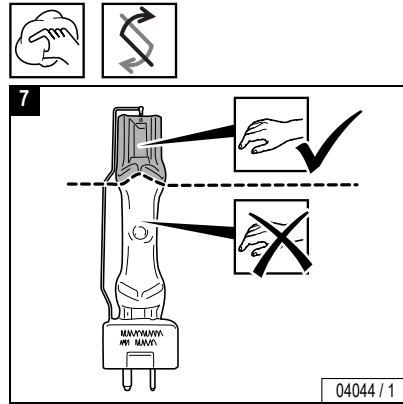
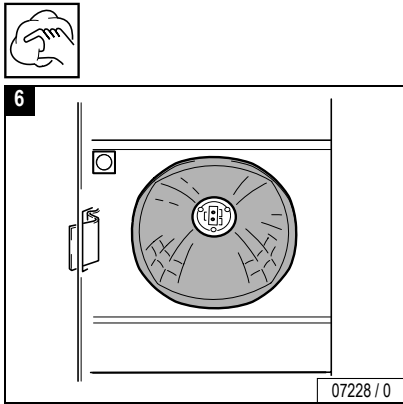

DANGER!

DANGER! Fire hazard!

High pressure lamps that have not been approved by Ergoline can explode. Hot lamp components can set other parts on fire. People can be killed or severely injured due to smoke and fume inhalation.

- Only fit high pressure lamps recommended by Ergoline.
- Clean the inside of the device regularly. Fluff is inflammable!



CAUTION!

Do not touch the glass bulbs of the UV high-pressure lamps with your bare fingers! Remove soiling thoroughly.

- Only touch new UV high-pressure lamp on the gripping surface – see Figures 8 and 9.

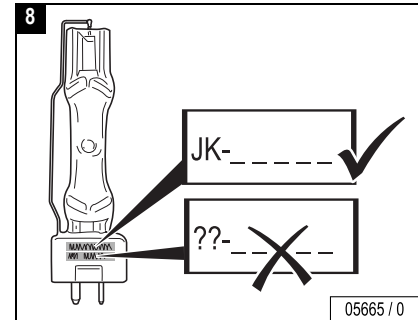

...

Cleaning/replacing UV high-pressure lamps and filter panels in the side section

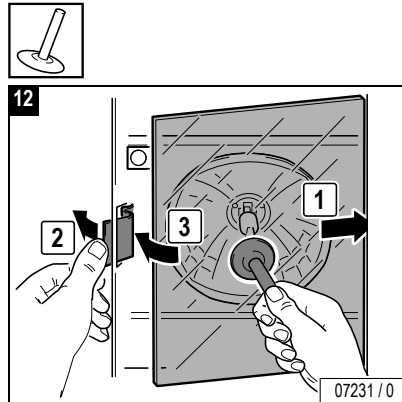
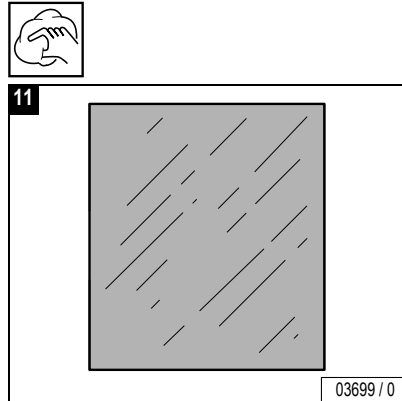
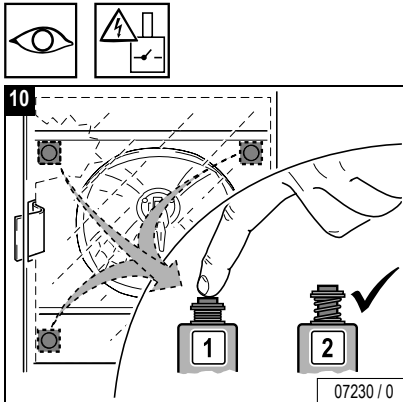
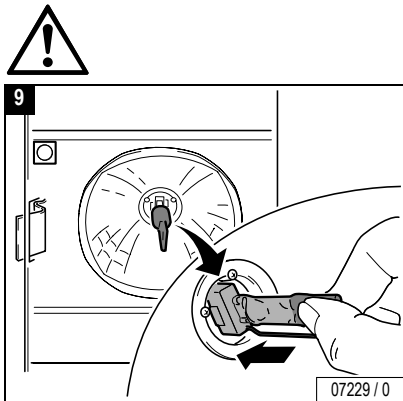

Close:

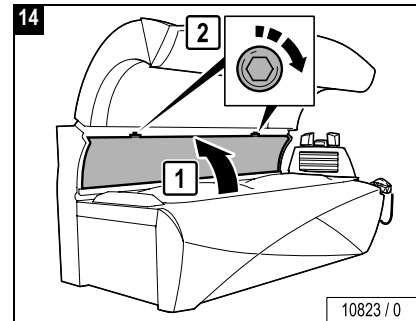

Cleaning or replacing UV high-pressure lamps and filter panels in the canopy

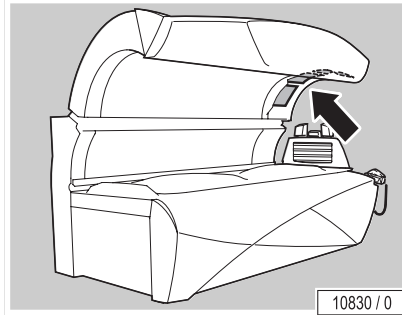
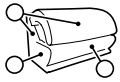

Danger of injury from the canopy panel!

WARNING! The canopy panel is heavy and falls down by itself after unscrewing the 3 screws.

- Support canopy panel.
- Loosen screws in the specified order.



Caution!

Canopy panel may break if allowed to fall or if pressure is exerted on the reverse side of an open canopy. Such failure is not covered by manufacturer's warranty.



Power Off!

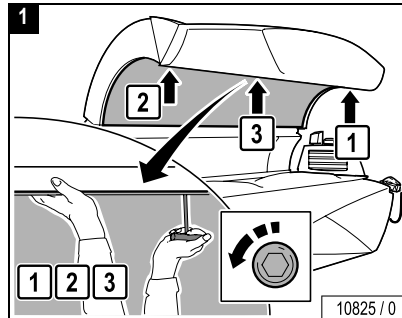

2

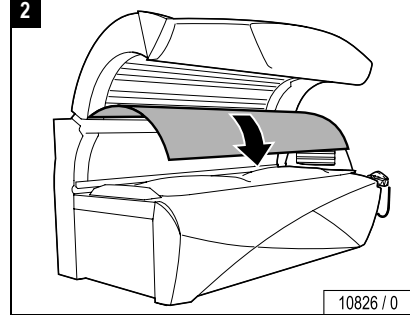

3

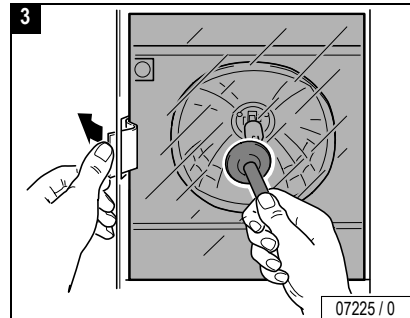

...

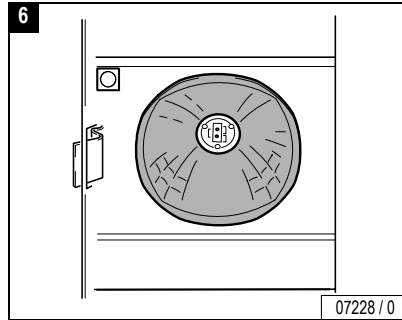
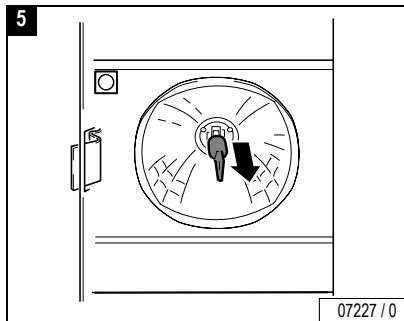
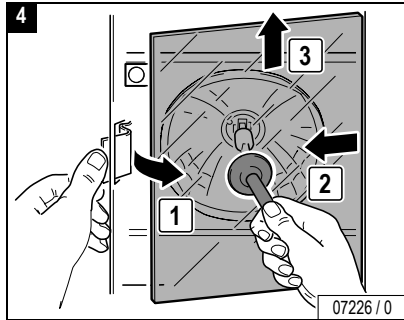

DANGER!

DANGER! Fire hazard!

High pressure lamps that have not been approved by Ergoline can explode. Hot lamp components can set other parts on fire. People can be killed or severely injured due to smoke and fume inhalation.

- Only fit high pressure lamps recommended by Ergoline.
- Clean the inside of the device regularly. Fluff is inflammable!

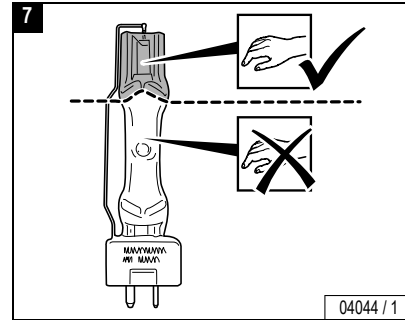

CAUTION!

Do not touch the glass bulbs of the UV high-pressure lamps with your bare fingers! Remove soiling thoroughly.

- Only touch new UV high-pressure lamp on the gripping surface – see Figures 8 and 9.



...

Cleaning or replacing UV high-pressure lamps and filter panels in the canopy

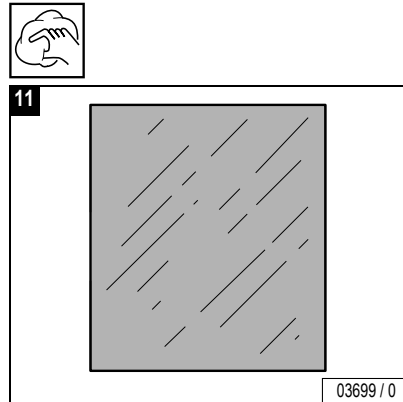
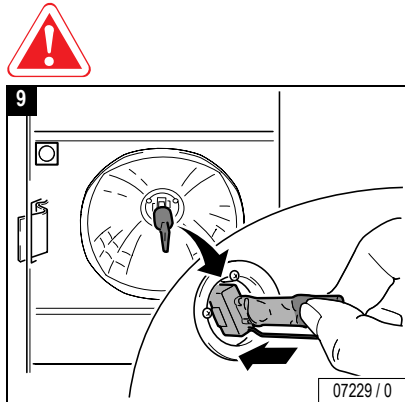
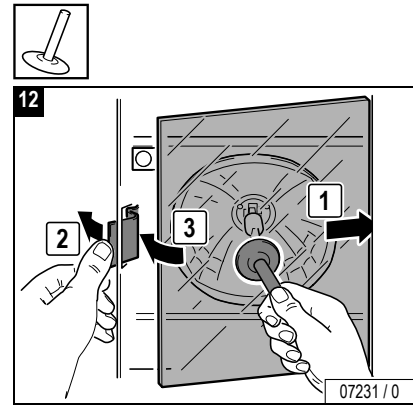
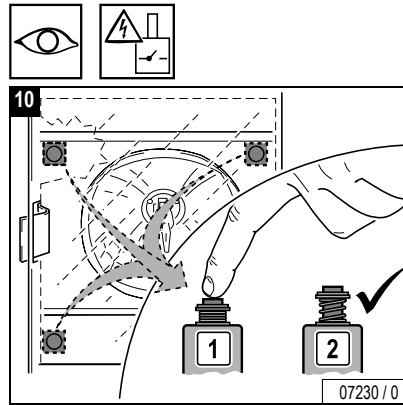
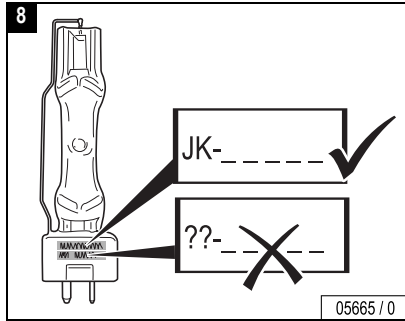

...

Cleaning or replacing UV high-pressure lamps and filter panels in the canopy

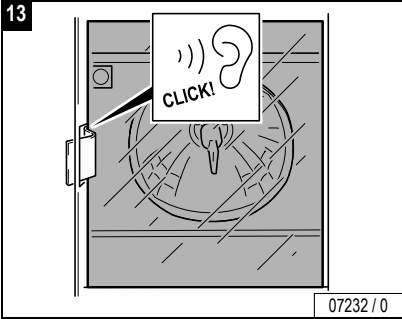

Close:

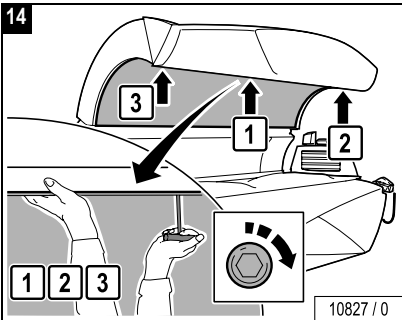

Cleaning/replacing accent lights in the canopy

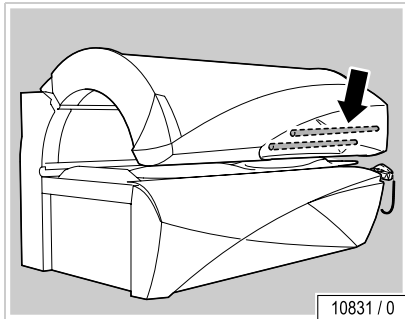
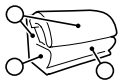

Caution!

Paint damage is possible! When screwing maintain a distance from the bottom edge.



Power Off!

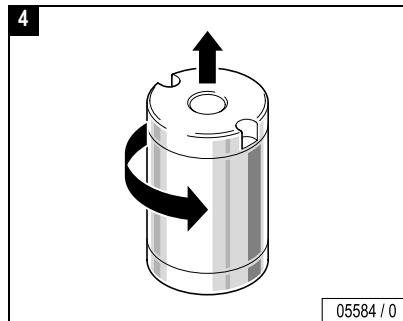
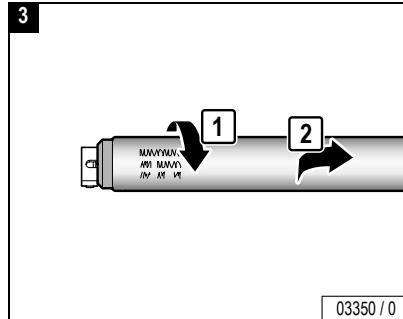
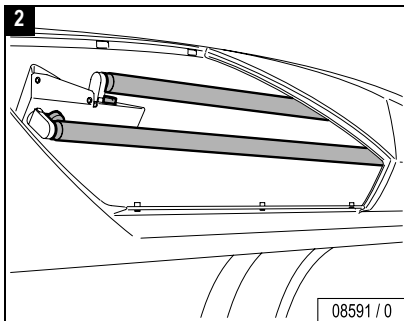
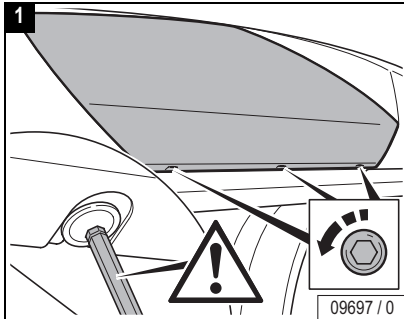

...

Cleaning/replacing accent lights in the canopy

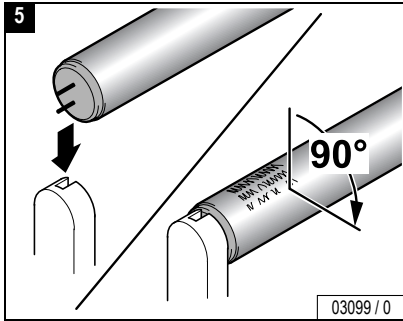

Close:

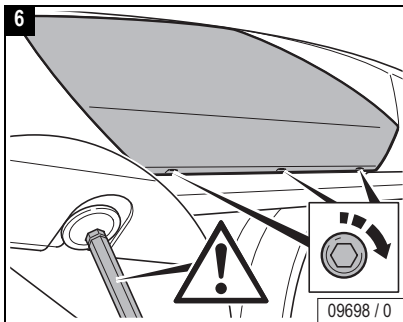

Cleaning/replacing accent light in front panel

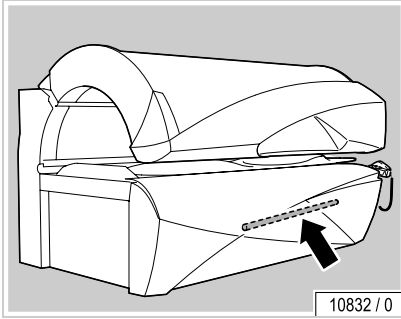
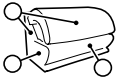

Power Off!

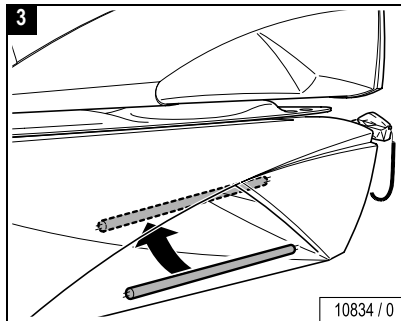
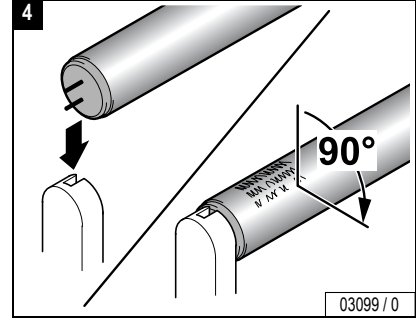
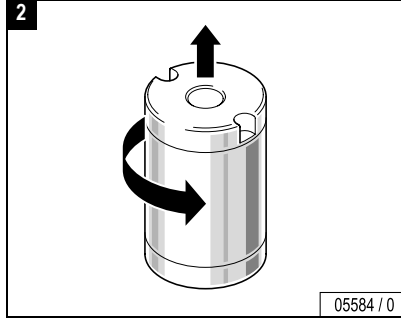
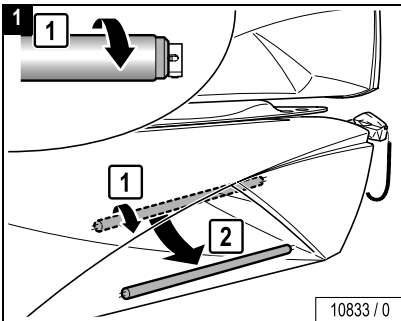

Cleaning/replacing ambient lights (optional)

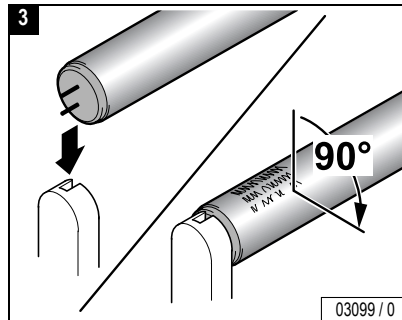
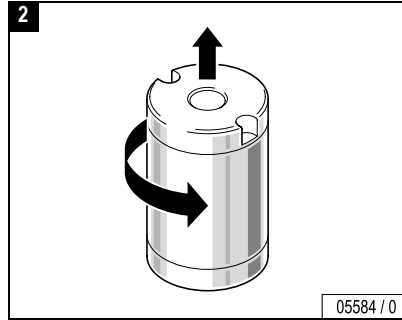
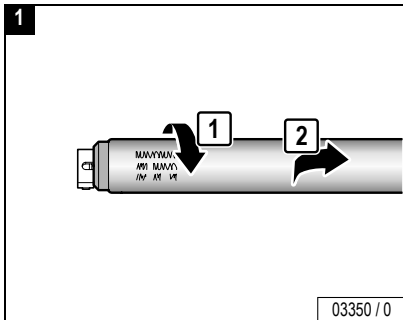
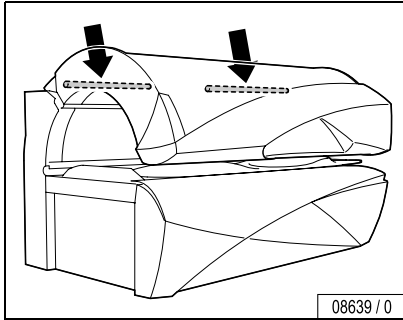

Cleaning the base filters

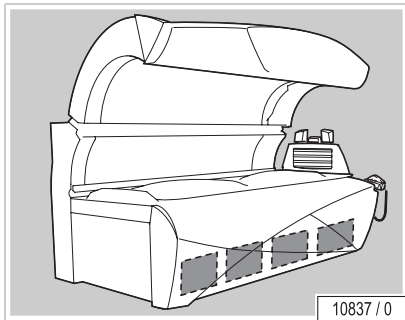
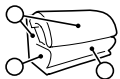

Power Off!

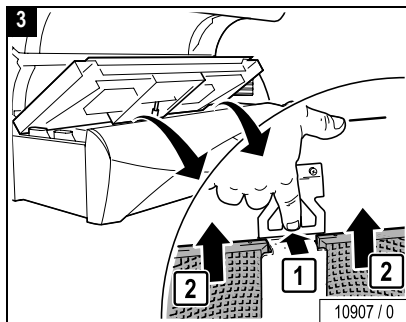
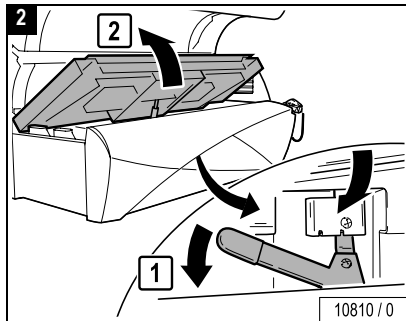
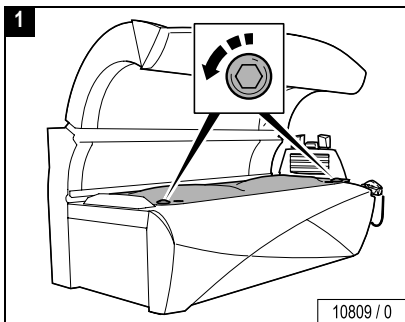

Hand-wipe lightly, dry or with water, or use a vacuum cleaner.

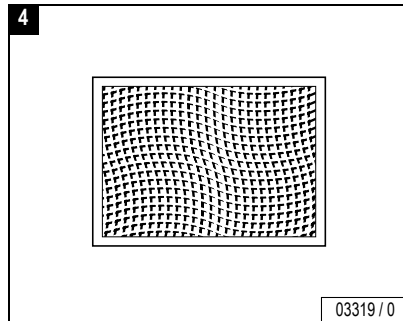

Attention! The system can be damaged by moisture!

When re-assembling, the cleaned filters must be dry.

...

Cleaning the base filters

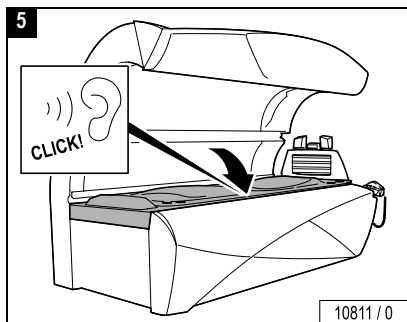
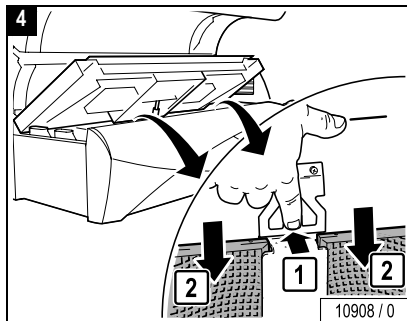

Close:

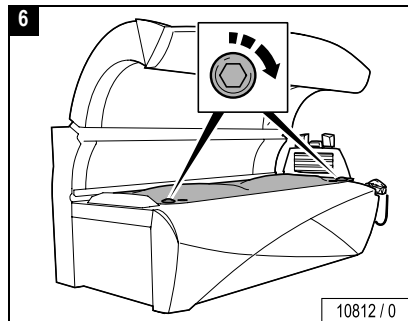

Cleaning/replacing filter mats in the canopy

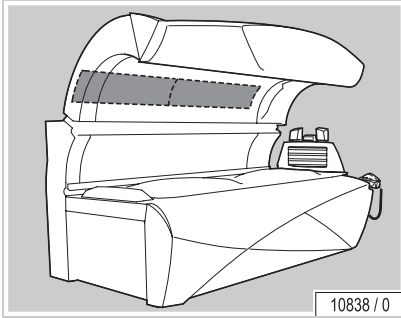
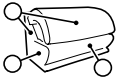

Rinse with water or replace.

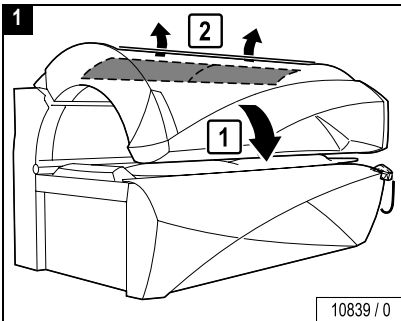
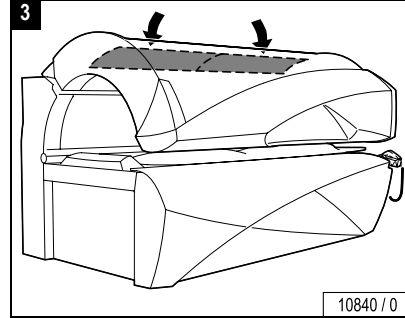
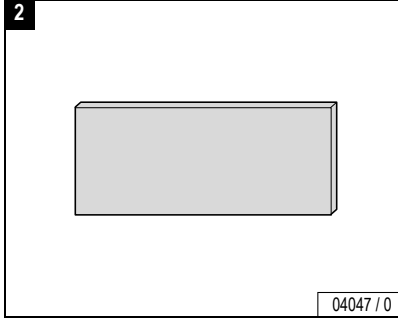

Attention! The system can be damaged by moisture!

When re-assembling, the cleaned filter mats must be dry.



Cleaning/replacing filter mats in shoulder tanner

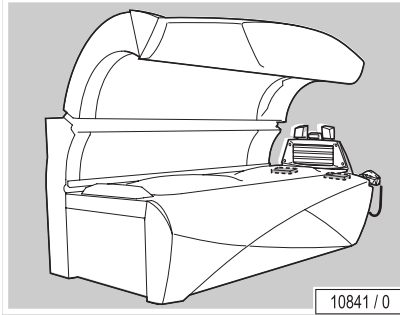
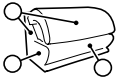

Power Off!

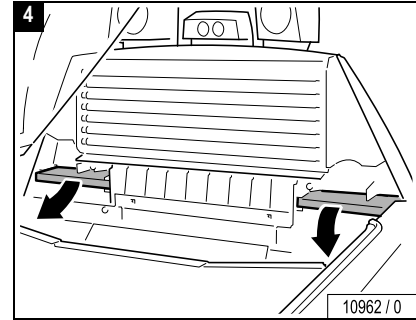
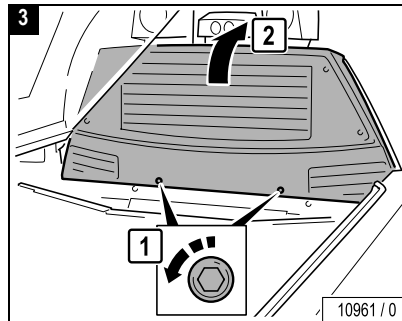
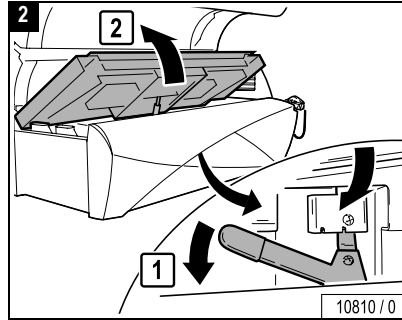
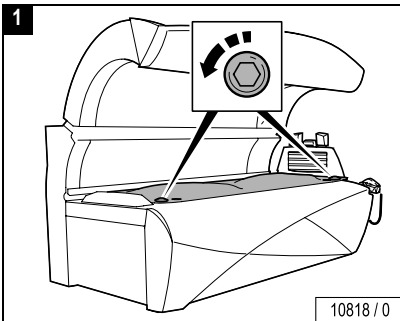

Rinse with water or replace.

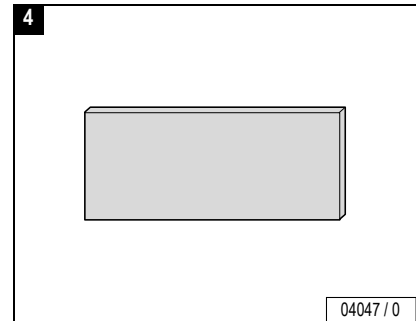

...



Attention! The system can be damaged by moisture!

When re-assembling, the cleaned filters and filter mats must be dry.

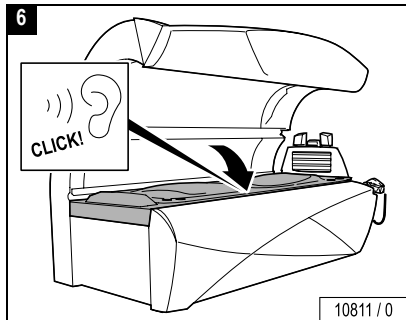
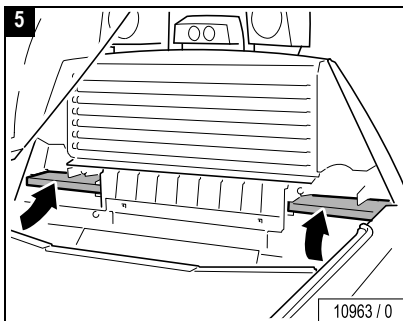

Close:

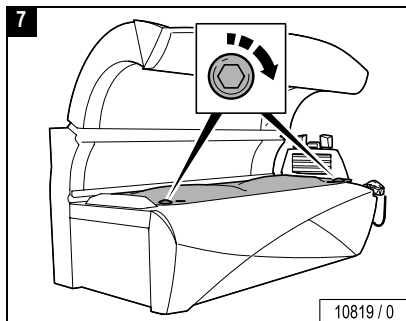

Temptronic: Emptying the condensation tank and cleaning the filter in the air condition



Regelmäßige Sichtprüfung!
Regular visual check!
Contrôle visuel régulier!

Gefahr von Geräteschäden!
Risk of damage to equipment!
Risque de détérioration de l'appareil!

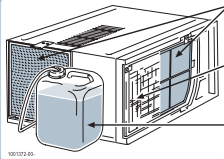

Filtermatten reinigen!
Renew filter mats!
Nettoyer les mats filtrants!

Kühlrippen reinigen!
Clean cooling fins!
Nettoyer les barres de refroidissement!

Kondensatbehälter entleeren!
Empty condensation container!
Vidanger le réservoir à condensation!

10822/00

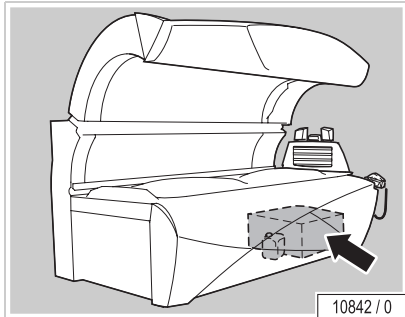
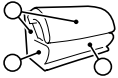

Power Off!

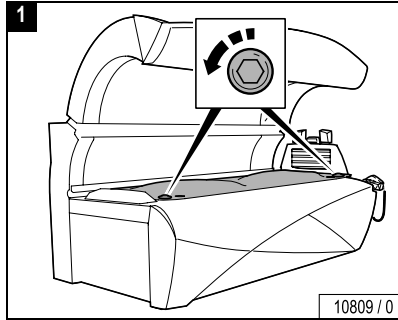

Attention! Risk of damage to the system!

Check the filter mat and the cooling fins on the air conditioner regularly and clean as necessary.

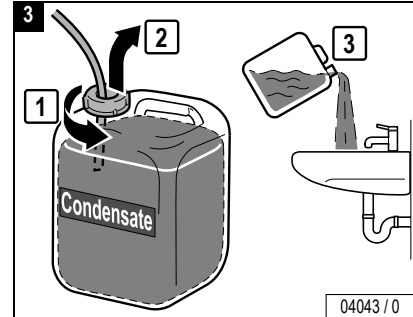
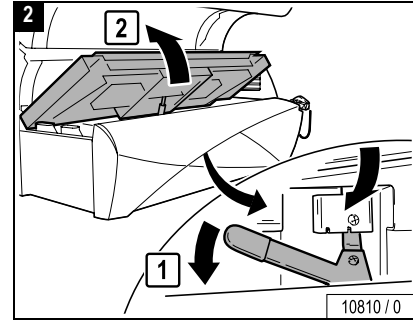

...

Tempronc: Emptying the condensation tank and cleaning the filter in the air condition

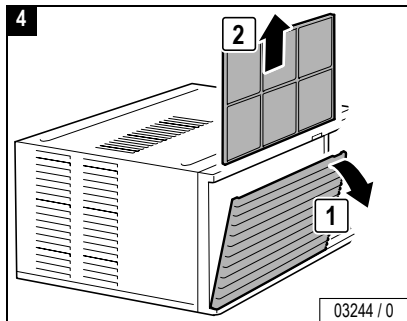

Clean carefully (vacuum or wash) or replace.

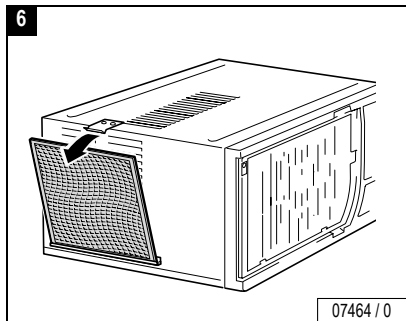
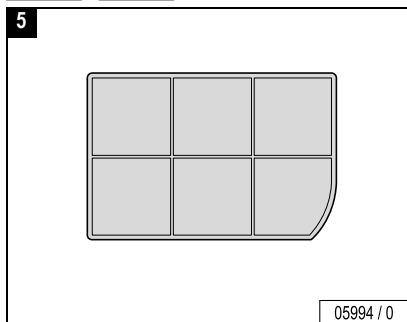

Hand-wipe lightly, dry or with water, or use a vacuum cleaner.

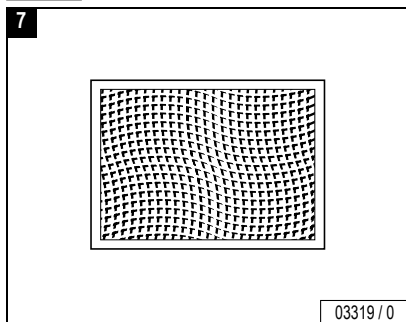

Clean carefully.

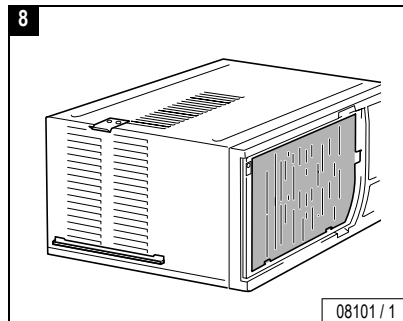

Attention! The system can be damaged by moisture!

When re-assembling, the cleaned filters and filter mats must be dry.

...

Tempronic: Emptying the condensation tank and cleaning the filter in the air condition

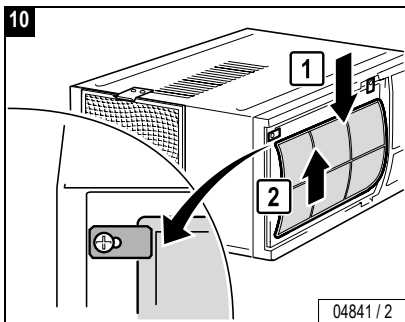
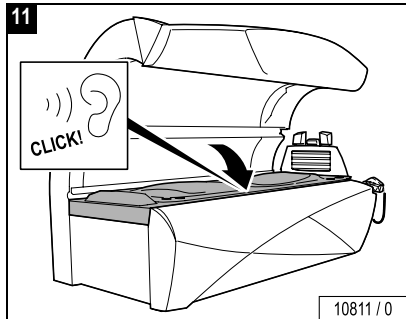
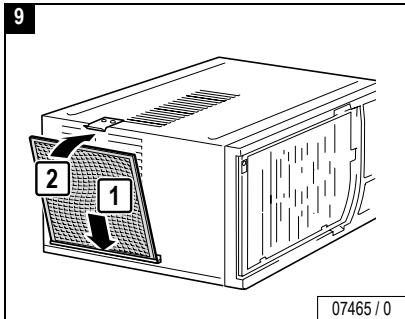

Close:

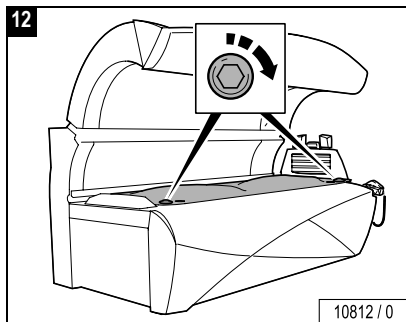

Replacing the AROMA tank

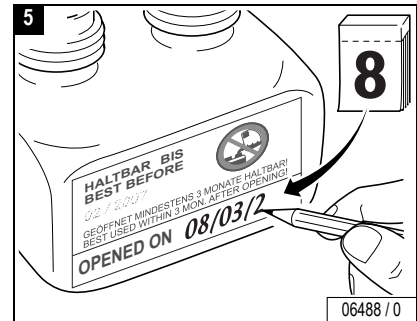
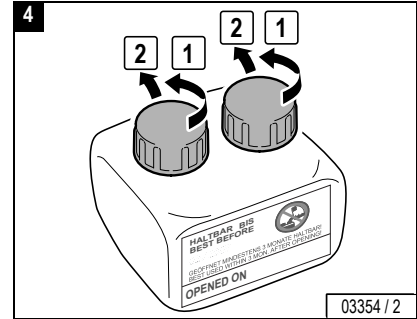
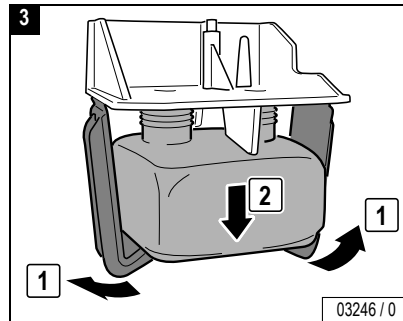
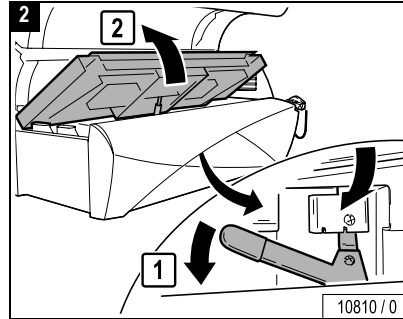
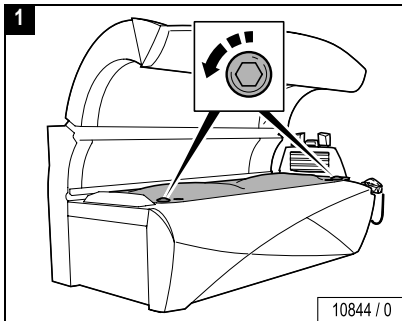
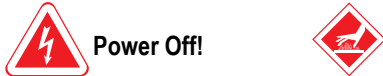
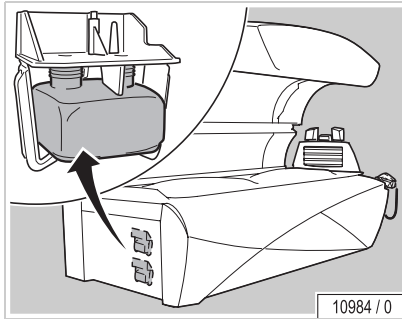
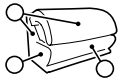

...

Replacing the AROMA tank

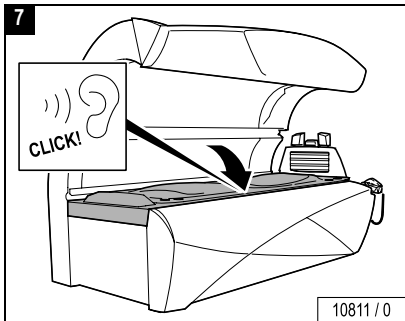
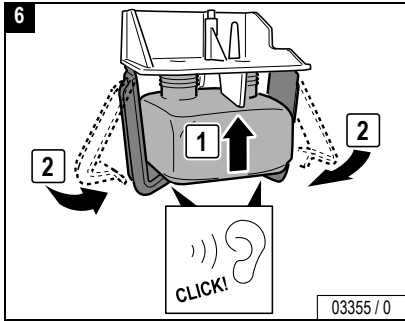

Close:

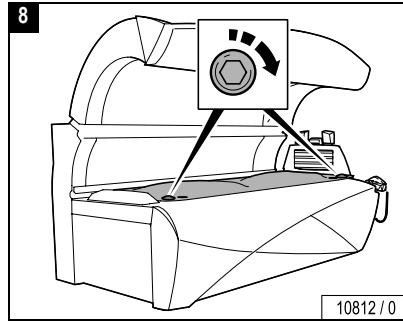

AQUA MIST system: Replacing the canister

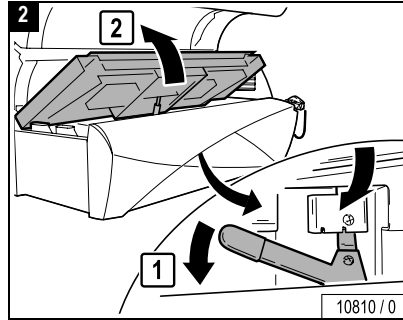
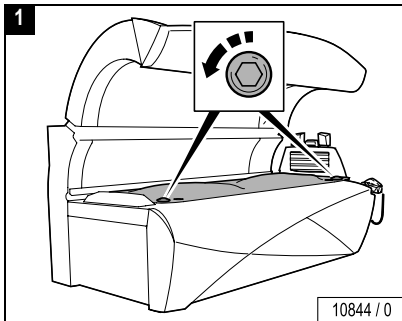
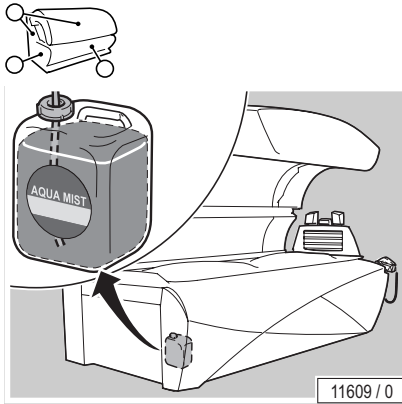

Health hazard!

Impurities in the AQUA MIST can present a health hazard.

- Use only original Sun Ergoline AQUA MIST!
- Replace the entire canister.
- Do not top up or mix with tap water or other liquids!
- Do not swallow!

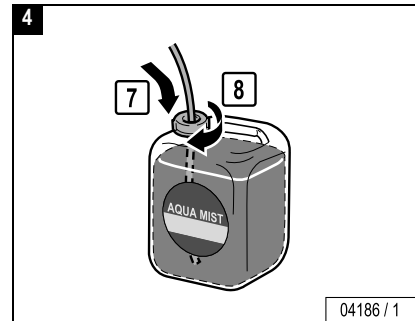
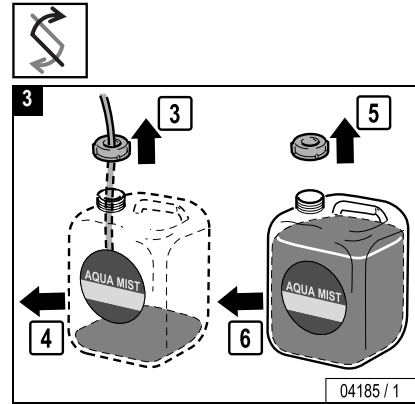

...

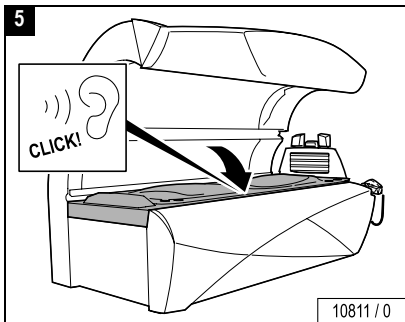

Close:

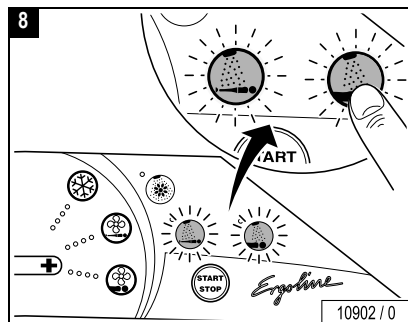
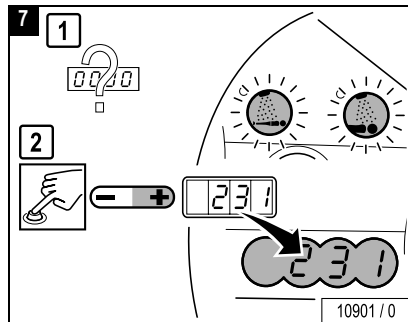
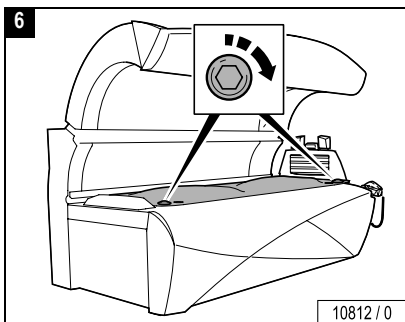

Note:

After replacing the canister, the system must be vented. To do this change to service mode and select function 231 (see separate instructions "Presettings", Order number 1001971).



...

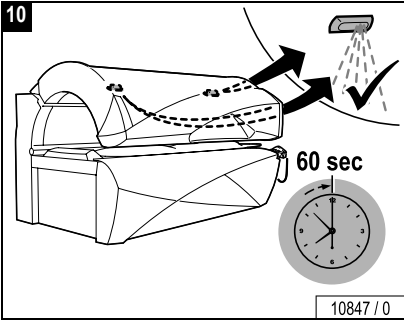
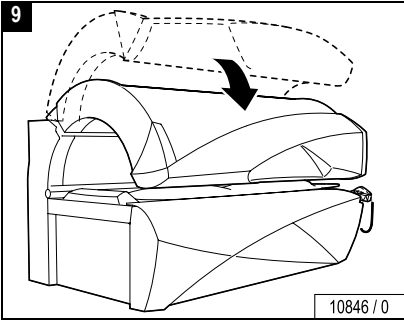

Connected load, power and noise level

Model:	Ergoline SUNANGEL S 46
Rated power consumption:	14,000 W
Rated voltage:	230 V
Rated frequency:	60 Hz
Rated fusing:	80 amp 3-pole
Conformity mark:	

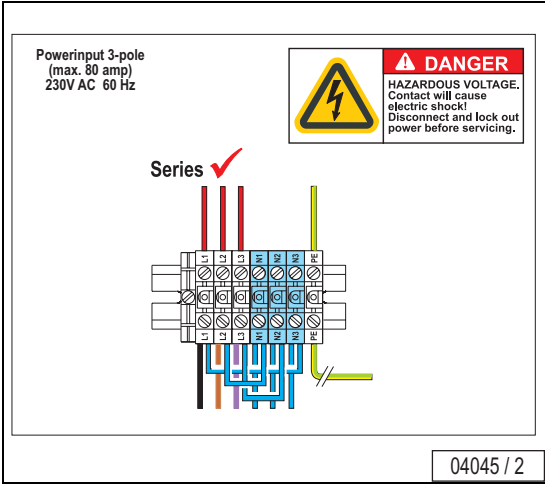

Installed lamps

Lamps, starters, filter panes

Order No. and lamp name **SUNANGEL S 46**

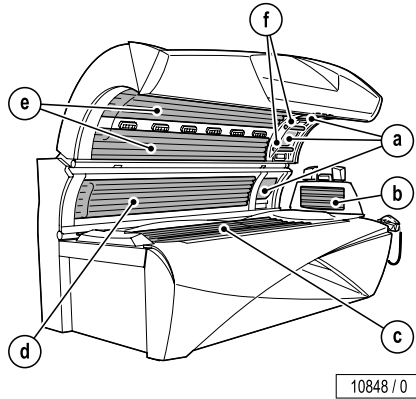



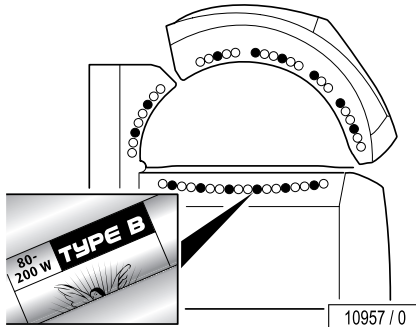





10848 / 0



10957 / 0



UV low-pressure lamps

c)	12 x		SUNANGEL Type A	200 W	1006083-..
	6 x		SUNANGEL Type B	200 W	1003958-..
d)	6 x		SUNANGEL Type A	200 W	1003957-..
	2 x		SUNANGEL Type B	200 W	1003958-..
e)	14 x		SUNANGEL Type A	200 W	1003957-..
	6 x		SUNANGEL Type B	200 W	1003958-..
f)	2 x		SUNANGEL Type B	8 W	1004102-..
b)	7 x		SUNANGEL	25 W	1003862-..

Starter

b) f)	9 x		S10	10047-..
-------	-----	---	-----	----------

UV high-pressure lamps



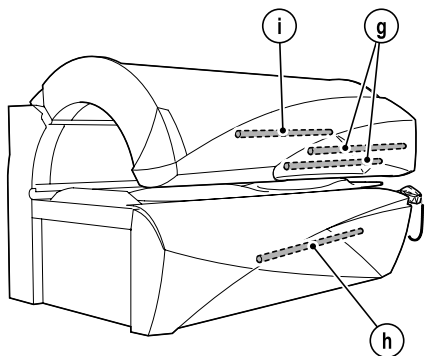

a)	3 x		Ergoline Ultra	520 W	12645-..
a)	3 x		Ultra Performance 862		1004204-..

Accent lights



10849 / 0

Standard lamps

g)	2 x		white	36 W	12969-..
h)	1 x		white	58 W	1004368-..
i)	2 x		white	30 W	1003445-..
j)	1 x		white	8 W	11839-..

Starter

g) h) i) j)	6 x		S10	10047-..
-------------	-----	---	-----	----------



Spare parts and accessories

Filters, AQUA MIST, AROMA

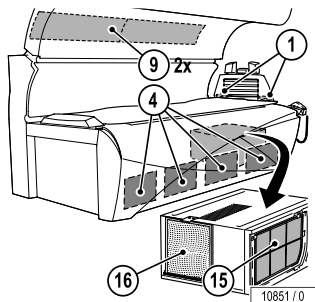

① 2 x 800278-..

④ 4 x 51937-..

⑨ 2 x 800601-..

⑮ 1 x 51975

⑯ 1 x 51937-..

⑤ 1 x 3652603-..

AQUA MIST, 6000 ml

⑥ a) 1004633-..

b) 1004633-..

AROMA, 100ml

a) Heaven

b) Heaven

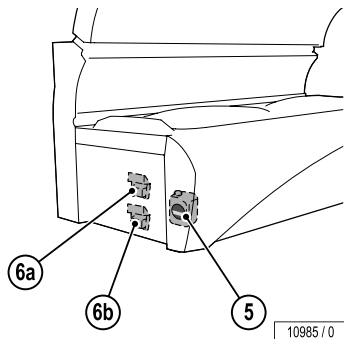

Acrylic glass

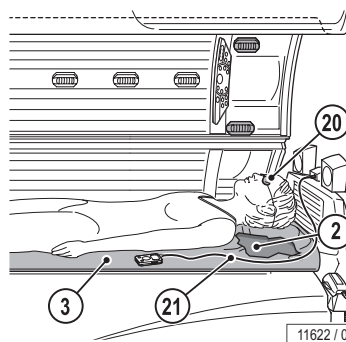

③ 1x 1000744-..

② 1x 800400-..

⑳ 1x 84592-..

㉑ 1x 1001855-..

Dimensions

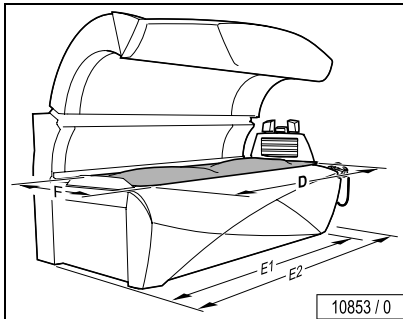
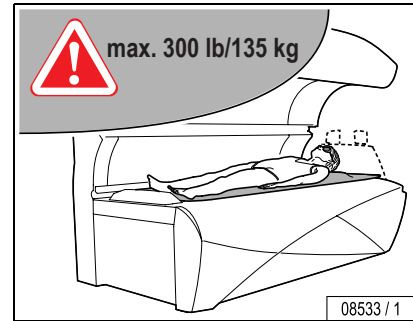
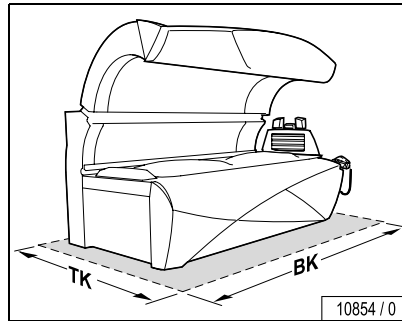
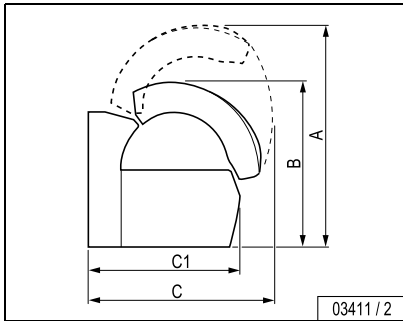

Sunangel S 46

A =	68 ¹ / ₂ in	1.740 mm
B =	52 ³ / ₄ in	1.340 mm
C =	55 ⁷ / ₈ in	1.420 mm
C1 =	52 ⁹ / ₁₆ in	1.335 mm
D =	78 ³ / ₄ in	2.000 mm
E1 =	89 in	2.260 mm
E2 =	92 ¹ / ₂ in	2.350 mm
F =	31 ¹ / ₂ in	800 mm
TK =	90 ⁹ / ₁₆ in	2.300 mm
BK =	94 ¹ / ₂ in	2.400 mm



Installation location

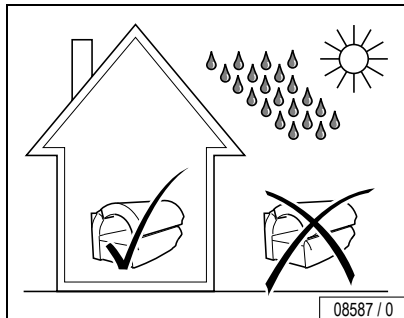
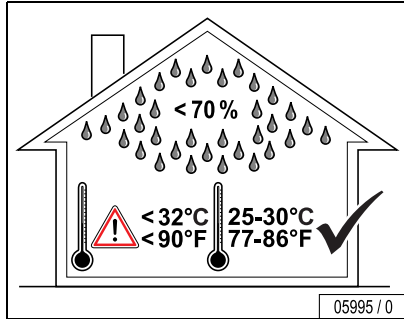

Ventilation



Attention! Danger of failure!

Non-observance of the ventilation information in the Ergoline Planning Manual can lead to serious system malfunctions.

Data for air supply and extraction planning can be found in the Ergoline Planning manual¹⁾ (www.sunergoline.com). You can also ask for this data from your sales agent or customer service (see Page 2).

Operating altitude

For altitudes greater than 2000 m above sea level a conversion must be carried out to ensure trouble-free operation. Please contact Customer Service (see Page 2) before carrying out the conversion and starting up the unit for the first time.

1) Order no. 801482

Acoustic level during tanning

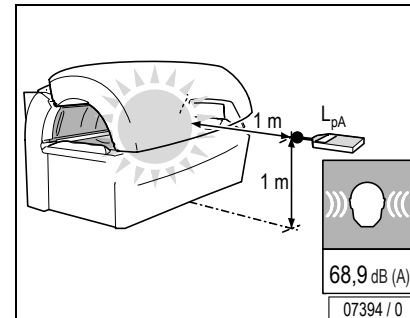
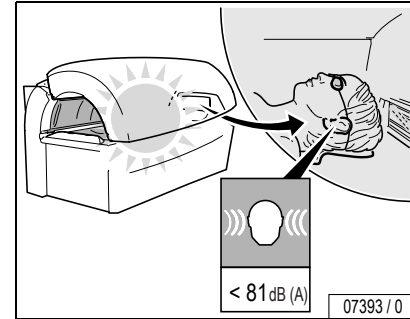

JK-Products, Inc. – Limited Warranty

JK-Products, Inc. warrants its products to be free from defects in materials and workmanship under intended normal use as described in the unit's Operation and Instruction Manual, for a period of three (3) years from date of sale.

This Limited Warranty applies only to the original purchaser of the equipment through JK-Products, Inc. or its authorized dealer or distributor, and is not transferable.

Global Service USA obligations under this warranty are limited to repair or replacement of any defective part without charge for that part to the original purchaser, with the following exceptions:

- A Fluorescent lamps are warranted against defects for a period of thirty (30) days from date of sale.
- B Only parts obtained through JK-Products, Inc., its authorized dealers or distributors may be used. Transportation costs for parts shipped to the consumer and the return of defective parts to Global Service USA are not included.
- C Labor will be furnished without charge for ninety (90) days from date of purchase only. All labor and related charges must be authorized by Global Service USA prior to start of repairs, and must coincide with Global Service USA established rates and time allotment policy.
- D Acrylic: Refer to Manufacturer's Acrylic Warranty Policy.

It is imperative that the original customer completes and returns the enclosed warranty card within 10 days after purchase to insure valid registration and coverage for potential claims.

If the warranty card is not registered, proof of purchase from JK-Products, Inc. or its authorized dealer or distributor will be required prior to any consideration on warranty claims. This could result in service delays.

This warranty is extended to the individual or legal entity, whose name appears on the warranty registration card filed with Global Service USA, or whose name appears on the original sale document and may not be transferred to any other individual or legal entity.

This warranty does not apply to any failure of the product, or any parts of the product due to alterations, modifications, misuse, abuse, accident, improper maintenance, improper installation, acts of God or if the serial number on the product has been removed, altered or defaced. Adequate packaging must be used for returned goods to prevent freight damage.

There are no warranties which extend beyond the description on the face hereof. There is no express or implied warranty of fitness of merchantability.

The remedies provided in this limited warranty are the exclusive remedies provided to the purchaser by Global Service USA and are provided in substitution of all other remedies. Consequential and incidental damages are excluded.

No person, firm or corporation is authorized to obligate JK-Products, Inc. for any liability in connection with the sale or use of these goods.



Limited Acrylic Warranty

JK Products, Inc. warrants its acrylic sheets to be free from defects in material and workmanship, under intended normal use, for a period of one (1) year from date of sale of the tanning bed. Due to the tanning lotions, cosmetics, disinfectant and improper cleaners used on tanning surfaces that cannot be controlled by JK Products, Inc., after the first thirty (30) days of warranty period acrylic will be subject to a prorated cost to the consumer.

JK Products, Inc. obligations do not include transportation charges on replacement acrylic.

JK Products, Inc. assumes no liability for the cost of removing defective sheets or installing replacement sheets, nor for damage to persons or property.

To make a claim, contact an authorized dealer or distributor of JK-Products, Inc. or Global Service USA with the model number, the serial number, and the date of purchase of the bed in which the acrylic will be used.

There are no warranties which extend beyond the description on the face hereof. There is no express or implied warranty of fitness or merchantability.

The remedies provided in this limited warranty are the exclusive remedies provided to the purchaser by Global Service USA and are provided in substitution of all other remedies. Consequential and incidental damages are excluded.

Global Service USA

A Div of JK Products & Services, Inc.
#1 Walter Kratz Drive
Jonesboro, AR 72401

☎ 800-445-0624

☎ 870-935-9046

e-mail: support@jkamerica.com

<http://support.jkamerica.com>



Warranty Claims

Policy & Procedures

1. When to file a Warranty Claim:

In the event that your tanning system is not functioning properly under intended normal use as described in the unit's Operation an Instruction Manual, you may then have established cause to file a Warranty Claim.



NOTE:

Both the tanning system and legal registered owner must meet the criteria established under JK Products, Inc. Limited Warranty as described in this manual before any Warranty Claim will be considered.

2. Where to call to place a Warranty Claim:

JK-Products, Inc. is supported nationwide by an extensive dealer/distributor network through whom the majority of our units are sold. These dealers/distributors are required by contract to stock sufficient parts to meet the various warranty and nonwarranty needs of their customers.

Therefore, in order for you to properly file a Warranty Claim, you must locate the name and phone number of the dealer/distributor through whom you purchased your unit. Normally this information can be easily located either on your paid invoice or other proof of purchase documentation that you received when taking delivery of the unit.

Next, notify the dealer/distributor of the serial number, model number and date unit was purchased. This will initiate the Warranty Claim process.

Upon determination of the problem, your dealer/distributor can then supply you with the part(s) and proper instructions to return your unit to working order.

Each dealer/distributor has their own internal procedure for handling Warranty Claims and credits.



NOTE:

JK-Products, Inc., the manufacturer, does not involve itself in the direct handling of a Warranty Claim except where mitigating circumstances apply and where required by law.



NOTE:

If part returned to Global Service USA proves to be operational and not defective, or if product code numbers on part do not correspond with individual unit date on file with Global Service USA, then a 30% restocking fee will be charged in addition to the retail purchase price of part.

Acknowledgment of the Agreement is not required for acceptance of the foregoing stipulations.

Labor Warranty Claim/Credit Procedures

Global Service USA furnishes labor without charge for a period of 90 days from date of purchase. All labor and related charges must be authorized by Global Service USA prior to start or repairs, and must coincide with Global Service USA established rates and time allotment policy. Please contact our Service Department for authorization and billing procedures.



Limited Lifetime Warranty

Global Service USA warrants specific individual components of the tanning system against defects in materials and workmanship for the life of the product. Coverage is limited to units purchased after November 1, 1994.

This warranty is restricted by the following components only:

- Steel Back Panels
- Structural Steel Frame Components
- Exterior Steel Body.



NOTE:

Components are warranted on an individual basis and not as they may effect the complete product.

Warranty coverage does not include cosmetic abnormalities such as scratches, nicks, dents, rust, oxidation of paint or other cosmetic changes that do not interfere with the designed function of the unit.

This warranty does not include failure of the product due to alteration, modifications, misuse, abuse, improper maintenance, improper installation or repair.

This warranty is not transferable and is only applicable to the original purchaser named on a completed and registered warranty record at JK-Products, Inc. headquarters.

JK Products, Inc. obligations do not include transportation charged on the shipping of new components to the customer or on the return of defective components of the manufacturer. All freight charges must be paid by the customer.

There are no warranties which extend beyond the description on the face hereof. There is no express or implied warranty of fitness or merchantability.

The remedies provided in this limited warranty are the exclusive remedies provided to the purchaser by Global Service USA and are provided in substitution of all other remedies. Consequential and incidental damages are excluded.



NOTE:

Any misuse, abuse, modification, alteration, improper maintenance, improper installation, etc. of this product or its intended use will subject said party to direct responsibility and liabilities for any and all consequences resulting from such action. Furthermore, such actions will void all warranties and may relieve Global Service USA of any liabilities relating to said product.



Index

A

Accent lighting, maintenance	98, 100
Accent lights	
Standard	116, 117
Accessories	21
Acrylic glass panel	
Allowable loading	119
Product information	68
Acrylic glass, cleaning	66
Air condition	
Cleaning the filters	107
Operation	37
Allergies	25
Ambient lights, cleaning/replacing	101
AQUA MIST AROMA system	118
AROMA tank	
replacing	110
Automatic mode	26, 30

B

Base filter	
Maintenance	102
Base, replacing the UV lamps	79
Body cooling	41

C

Cabin lighting, cleaning/replacing	101
Canopy	
Replacing the UV lamps	85

Canopy, interior lighting	89
Care	61, 66
Channel	55
Chip card of lamp set, insertion	77
Cleaning	66
Base station	76
Lamps, filter panels	67
Sensor	76
Cleaning intervals	69
Conformity mark	115
Connected load	115
Contact lenses	25
Control elements	23

D

Description	20
Dimensions	119
Disinfection	66
Disposal of lamps	18

E

Empty the condensation tank	107
Ending tanning session	28
Environmental protection	18
Equipment	19

F

Facial tanner	
Operation	32
Replacing high pressure lamps	94
Replacing the UV lamps	87
Filter mats	
Canopy	104
Filter panels	
Maintenance	91, 94
Filter panes	116
First tanning session	26, 29
Frequency	115
Fusing	115

G

Glasses	25
Global Service USA, address	2
Guidelines	16

I

Installation location	120
Installed lamps	116
Intended use	16
Interior lighting, maintenance	89
Interrupting tanning session	28

L

Lamp configuration	116
Lamps, disposal	18

Listening to Info texts.....	53	Preparation time.....	26	T	
M		Proper use.....	16	Tanning	25
Maintenance	65	Protective goggles.....	25, 26	Tanning instructions	25
Maintenance and care	61	R		Technical data	115
Safety information.....	75	Relamping	75	Temperature, regulating	37
Maintenance intervals.....	69	Running time of accent lighting	60	Temptronic, cleaning the filters	107
Maintenance overview	65	S		Temptronic, operation	37
Make-up.....	25	Safety information, maintenance.....	75	Test session	29
Malfunctions.....	64	Selecting audio system	55	Test tanning session	26
Medication	25	Shoulder tanner		Timer	26
MP3 music, product information	17	Filter mats.....	105	U	
MP3 player connection	49	Replacing the UV lamps.....	81	Using the sunbed	25
Music channel, choosing	55	Shoulder tanner, operation.....	35	UV low pressure lamps	
N		Showering	25	replacing.....	79, 81, 85, 87
Noise level	115	Side section		UV low-pressure lamps	
O		Replacing high-pressure lamps.....	91	Side section	83
Operating altitude	120	Skin sensitivity.....	25	V	
Operation overview	23	Skin types.....	3	Ventilation data, see Planning Manual	120
Operator commitments	16	Spare parts.....	61	Voice Guide.....	51
Order numbers.....	118	Order-No.	118	Voltage	115
P		Starter	116	Volume	58
Packaging	18	Starting tanning.....	26		
Plastic surfaces.....	67	Sunbed description	20		
Power.....	115	Sunbed, how to use it.....	25		
Power consumption	115	Switching AQUA MIST on.....	45, 47		
Power, switching off.....	63	Switching off the sound.....	58		
		Switching on AROMA.....	43		



NO POSTAGE
NECESSARY
IF MAILED
IN THE
UNITED STATES

BUSINESS REPLY MAIL
FIRST-CLASS MAIL PERMIT NO 295 JONESBORO AR

POSTAGE WILL BE PAID BY THE ADDRESSEE

JK PRODUCTS & SERVICES, INC.
#1 WALTER KRATZ DRIVE
JONESBORO, AR 72401

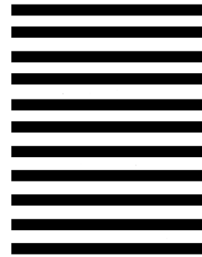

Separate here



SUN | **DASH**
PERFORMANCE | TANNING

soltron

Ergoline

Ⓐ WARRANTY REGISTRATION

Please complete the warranty section below. To validate and insure proper coverage, card must be completed and returned within ten (10) days of the date of purchase.

_____/_____/_____
Name of Purchaser Date of Purchase

Street Address or P. O. Box

City State Zip

()

Phone Number with area code

Company unit purchased from and amount paid.

Name of Business (if applicable)

E-mail

Circle Answers:

Type of Business:

Tanning Salon Video Store Health Club Beauty Salon

Other _____

Number of tanning beds at this location:

1-3 4-7 8-15 16-25 >25

If you experience any difficulties obtaining replacement parts from your distributor, please call Sun Ergoline at 800-643-0086, choose option 5.

Year & Model #

Serial #

SUN ERGOLINE, A DIVISION OF JK-PRODUCTS & SERVICES, INC.

1 Walter Kratz Drive · Jonesboro, AR 72401

Phone: 800.643.0086 (Toll-free) · Email: ergoline@sunergoline.com

Fax: 870.935.3618 · Website: www.sunergoline.com

Ergoline